



EDITION: 04/2007

**Code:** D-LBR447

This manual has been prepared and printed by Robur S.p.A.; whole or partial reproduction of this manual is prohibited.

The original is filed on the premises of Robur S.p.A.

Any use of this manual other than for personal consultation must be previously authorised by Robur S.p.A.

The rights of those who have legitimately filed the registered trademarks contained within this publication are not affected.

With the aim of continuously improving the quality of its products, Robur S.p.A. reserves the right to modify the data and contents of this manual without prior notice.

## INTRODUCTION

This manual is intended for those who must install and use the Robur M C series warm air heaters.

It is directed to the hydraulic system installation technicians who must install the heater, the electrical system installation technicians who must connect the heater to the main power supply and to the end users who must verify its normal operation.

The manual is also for service technicians with indications of maintenance and technical assistance operations.

### Summary

The manual is divided into six sections:

Section 1 is for the **user**, the **hydraulic system installation technician**, the **electrical system installation technician** and the **service technician**. It provides general warnings and observations, technical data and the manufacturing characteristics of the M C series heaters.

Section 2 is for the **user**. It provides all the information that is necessary to use the M C series heaters correctly.

Section 3 is for the **hydraulic installation technician**. It provides all the information that is necessary for the correct installation of the M C series heaters.

Section 4 is for the **electrical system installation technician**. It provides all the information that is necessary to make the electrical connections for the M C series heaters.





Section 5 is for **service technicians**. It provides instructions for regulating gas flow and for changing gas type. It also contains information regarding maintenance.

Section 6 is for the **user**, the **hydraulic system installation technician**, the **electrical system installation technician** and the **service technician**. It contains information about accessories available for the M C series heaters.

For rapid access to the sections, refer to the relative graphical icons (see Table 2) indicated in the right-hand margin of the odd-numbered pages.

## Meaning of icons

The icons contained in the margin of the manual have the following meanings.

	Danger signal
	Warning
	Notes
	Start of operating procedure
	Reference to another part of the manual or to another manual/booklet

**Table 1** – Descriptive icons

	Section 1: Overview and technical characteristics
	Section 2: User
	Section 3: Hydraulic system installation technician
	Section 4: Electrical system installation technician
	Section 5: Technical assistance and maintenance
	Section 6: Accessories

**Table 2** – Section icons

## INDEX OF CONTENTS

<b>SECTION 1: OVERVIEW &amp; TECHNICAL CHARACTERISTICS .....</b>	<b>7</b>
1.1 GENERAL ADVICE.....	7
1.2 NOTES ON OPERATION OF THE APPLIANCE.....	9
1.3 MANUFACTURING CHARACTERISTICS .....	10
CONTROL AND SAFETY COMPONENTS.....	10
1.4 TECHNICAL DATA .....	11
1.5 DIMENSIONS OF M C SERIES HEATERS .....	12
<b>SECTION 2: USER.....</b>	<b>13</b>
2.1 HOW TO SWITCH THE HEATER ON AND OFF .....	13
WINTER OPERATION (HEATING).....	13
SWITCHING OFF .....	14
SUMMER OPERATION (VENTILATION).....	14
SEASONAL SWITCH-OFF .....	14
<b>SECTION 3: HYDRAULIC SYSTEM INSTALLATION TECHNICIAN .....</b>	<b>15</b>
3.1 GENERAL APPLIANCE INSTALLATION PRINCIPLES.....	15
3.2 INSTALLATION SEQUENCE .....	15
3.3 SIZING OF COMBUSTION AIR AND FLUE PIPES .....	17
EXAMPLE OF CALCULATION.....	24
3.4 INSTALLATION OF FLUE DIAPHRAGM.....	24
3.5 AIR CHANGES.....	25
3.6 WALL INSTALLATION WITH SUPPORT BRACKET .....	26
<b>SECTION 4: ELECTRICAL SYSTEM INSTALLATION TECHNICIAN .....</b>	<b>27</b>
4.1 HOW TO CONNECT THE HEATER TO THE POWER SUPPLY .....	27
4.2 HOW TO INSTALL THE CONTROL BOX .....	27
4.3 HOW TO CONNECT THE THERMOSTAT TO THE HEATER.....	28
4.4 HOW TO MAKE THE ELECTRICAL CONNECTION FOR SUMMER OPERATION .....	29
4.5 ASSEMBLY WIRING DIAGRAM.....	30
4.6 OPERATION WIRING DIAGRAM.....	31
4.7 ELECTRICAL CONNECTION DIAGRAM FOR SUMMER/WINTER SWITCH AND PROGRAMMABLE TIMER .....	31
4.8 WIRING DIAGRAM FOR CONNECTION OF SEVERAL HEATERS .....	32
<b>SECTION 5: TECHNICAL ASSISTANCE AND MAINTENANCE .....</b>	<b>35</b>
5.1 HOW TO REGULATE THE GAS VALVE.....	35
OPERATION WITH NATURAL GAS .....	35
OPERATION WITH L.P.G. GAS.....	36
REGULATION OF SOFT OPENING (FOR M 60 C HEATERS).....	36
5.2 HOW TO CHANGE GAS TYPE .....	38
5.3 MAINTENANCE .....	39
5.4 OPERATING ANOMALIES .....	39
5.5 TYPES OF FAULT AND POSSIBLE ACTIONS .....	39
CASE NO. 1: THE UNIT LOCKS OUT DURING THE FIRST IGNITION PHASE. ....	39
CASE NO. 2: THE UNIT LOCKS OUT DURING OPERATION. ....	40
CASE NO. 3: THE TEMPERATURE LIMIT THERMOSTAT (M1) STOPS THE BURNER. ....	40
CASE NO. 4: THE BURNER GOES OUT AND DOES NOT RE-IGNITE EVEN IF ROOM TEMPERATURE REQUIRES IT.....	40
CASE NO. 5: THE EXHAUST FAN WILL NOT START.....	40
CASE NO. 6: THE EXHAUST FAN STARTS BUT THE UNIT DOES NOT IGNITE.....	41
<b>SECTION 6: ACCESSORIES.....</b>	<b>45</b>

MIXING CHAMBER .....	45
FILTER HOLDER.....	45
AIR FILTER.....	46
AIR FLOW ADJUSTMENT DAMPERS.....	46
ANTI-VIBRATION JOINTS.....	47
LOWER SUPPORT BEAMS .....	47
SUPPORT BRACKETS .....	47



## SECTION 1: OVERVIEW & TECHNICAL CHARACTERISTICS

In this section you will find general indications to follow regarding the installation and use of the M C series heaters, a brief overview of the operation of the heaters, their manufacturing characteristics and technical data.

### 1.1 GENERAL ADVICE

This manual is an integral and essential part of the product and must be delivered to the final user.

This appliance must be used only for the purposes for which it has been expressly designed for. All other uses are considered inappropriate and therefore dangerous.

The manufacturer does not accept any contractual or extra contractual liability for damage caused by errors in installation or use and in any case by failure to observe the instructions supplied by the manufacturer.

The appliance must be installed in compliance with current regulations.

Do not obstruct either the intake hole or the outlet grilles of the fan.



In the case of failure and/or poor operation of the appliance, deactivate it (disconnect the power supply and close the gas valve), and refrain from any attempt to repair or intervene directly upon the appliance.

Any product repairs must only be carried out by a **Technical Assistance Centre** authorised by the manufacturer, and using only original spare parts.

Failure to observe the instructions above may compromise the safety of the appliance.

To guarantee the efficiency and correct operation of the appliance it is essential to have annual maintenance carried out by **professionally qualified personnel**, observing the manufacturer's instructions.



**Professionally qualified personnel** means personnel that have specific technical expertise in the sector of heating plant components for civil use. In any case the user may obtain all necessary information by contacting ROBUR S.p.A. Customer Service Department (tel. 0039 035 888111).

If the appliance is sold or transferred to a different owner, ensure that this manual accompanies the appliance, so that it may be consulted by the new owner or installation technician.

Before starting the heater, have **professionally qualified personnel** check that:

- mains power and gas mains data correspond to data on the appliance's data plate;
- the flue pipe is functioning efficiently;
- combustion air is supplied and exhaust gases are expelled correctly in accordance with current regulations;
- the gas supply plant is correctly sealed both internally and externally;
- fuel intake flow is regulated in accordance with the power required by the heater;

- the heater is supplied with fuel type for which it is set up for;
- the fuel supply pressure is within the values given on the data plate;
- the fuel supply plant is sized for the flow required by the heater and that it is equipped with all of the safety and control devices prescribed by current regulations.

Do not use gas pipes to ground electrical devices.

Do not leave the heater connected to the power supply unnecessarily when not in use, and close the gas valve.

If the appliance is not to be used for a long period, close the heater's main gas supply valve and disconnect it from the power supply.



### **IF YOU SMELL GAS**

- Do not use electrical switches, telephones or any other object or device that can cause sparks.
- Close the gas valve.
- Open doors and windows immediately in order to create an air current to ventilate the room.
- Contact professionally qualified personnel for assistance.



## 1.2 NOTES ON OPERATION OF THE APPLIANCE

The M C series warm air heater is an independent heating appliance with a sealed circuit, forced draught type.

It has been designed to be installed inside the room to be heated and warm air is distributed through a connected air duct.

It can operate with natural gas (G20) and L.P.G. (G30/G31) (appliance belonging to category II<sub>2H3+</sub> in compliance with norm EN 1020).

The combustion circuit is sealed off from the environment to be heated and complies with the requirements of norm EN 1020 for type C appliances: intake of combustion air and outlet of exhaust gases occur outdoor and are ensured by the operation of a blower which is located in the combustion circuit. The appliance is approved also as a type B appliance for installations where the combustion air intake is permitted directly from the room to be heated.

The operation of the generator is controlled by a thermostat, available as an accessory. When heat is required, the electronic control unit ignites the burner.

An electrode detects when ignition has occurred. If there is no flame, the electronic control unit stops the appliance.

The combustion products pass through the heat exchangers internally the unit. The heat exchangers receive externally the flow of air produced by the centrifugal fan causing warm air to circulate in the room.

The centrifugal fan starts automatically only when it receives the command from the ventilation thermostat, that is, only when the exchangers are hot, in order to prevent cold air from being introduced into the room. It stops when the exchangers are cold.

If the heat exchangers should overheat, because of abnormal operation, a limit thermostat is fitted in the unit which, if required, cuts off power to the gas valve, which then cuts off the flow of fuel and causes the burner to switch off. The limit thermostat can be reset manually.



The limit thermostat may be reset only by **professionally qualified personnel** when the cause of overheating has been identified.

If the air intake or flue pipes are obstructed, or if the flue fan does not function properly, the differential manostat intervenes, causing the stop of the gas valve and the subsequent switching off of the heater.

If during the summer period the operation of only the fan(s) is required, it is possible to replace the command supplied as standard with a command with a summer/winter switch (available as an accessory).

## 1.3 MANUFACTURING CHARACTERISTICS

M C series heaters are supplied with:

- **atmospheric burner**, patented by ROBUR, in AISI 430 stainless steel
- **combustion product extractor** for forced draught of combustion products
- cylindrical **combustion chamber** in AISI 409 stainless steel, manufactured with non-welded seams
- **heat exchanger**, patented by ROBUR, in aluminium alloy with high heat exchange capacity with horizontal fins (air side) and vertical fins (flue side)
- **self-supporting structure** in sheet stainless steel painted with RAL 2008 orange epoxy powder
- **connector flange** for connection to warm air distribution ducting
- **centrifugal fan** for introducing warm air into the room
- **control box** with lock out signal and reset button

### CONTROL AND SAFETY COMPONENTS

- 100 °C manual reset **limit thermostat** to protect against overheating of the heat exchangers
- manual reset **safety thermostat** to protect against overheating of the electrical panel
- **fan thermostat** to control the start-up of the fan only when the exchangers are hot, to prevent cold air being blown into the room
- **differential manostat** to control the correct expulsion of combustion products
- **gas electro valve**: if a safety device intervenes (e.g. limit thermostat, safety thermostat, etc.) the gas valve is locked out electrically with the consequent block of gas flow to the burner.
  - Voltage: 230 V - 50 Hz
  - Operating temperature range: 0 °C up to +60 °C
  - Model: SIT 830 Tandem (for models 20 and 30)  
SIT 826 Tandem (for models 60)
- **electronic flame control unit** for controlling the ignition of the main burner and checking for presence of a flame by means of an ionisation-based electrode. If no flame is present, the device causes the gas valve to be closed.



## 1.4 TECHNICAL DATA

MODEL	U.M.	M20 C	M30 C	M60 C	
APPLIANCE CATEGORY		II <sub>2</sub> H <sub>3</sub> +			
APPLIANCE TYPE		C12 – C32 – B22			
GAS TYPE		Natural gas – LPG			
NOMINAL HEAT INPUT	kW	20.6	34.8	72.5	
NOMINAL HEATING OUTPUT	kW	18.3	30.7	63.8	
PRESSURE HEAD	Pa	110			
NOMINAL GAS CONSUMPTION (15° C – 1013 mbar)	NATURAL GAS	m <sup>3</sup> /h	218	3.68	7.67
	L.P.G. G30	kg/h	1.62	2.74	5.72
	L.P.G. G31	kg/h	1.59	2.69	5.61
NOMINAL EFFICIENCY	%	88.8	88.2	88	
FUEL SUPPLY PRESSURE	NATURAL GAS	mbar	20		
	L.P.G. G30		28/30		
	L.P.G. G31		37		
GAS INLET DIAMETER	"	1/2		3/4	
COMBUSTION AIR INTAKE PIPE DIAMETER	mm	130			
FLUE PIPE DIAMETER	mm	110			
VOLTAGE		230V – 50 Hz			
INSTALLED ELECTRICAL POWER	W	600	620	920	
FUSE	A	6.3		10.0	
AIR FLOW RATE <sup>(1)</sup> AT MAXIMUM PRESSURE DROP AT MINIMUM PRESSURE DROP	m <sup>3</sup> /h	1600	3100	5800	
		2900	4300	7600	
THERMAL HEAD AT MAXIMUM PRESSURE DROP AT MINIMUM PRESSURE DROP	K	34	29.3	32.6	
		18.7	21.1	24.9	
SOUND PRESSURE LEVEL AT 6 METRES IN FREE-FIELD CONDITIONS (MAX FLOW)	dB(A)	43.5	47	50	
WEIGHT	kg	66	82	133	

**Table 3** – Technical data

<sup>1</sup> At 20 °C – 1013 mbar

### 1.5 DIMENSIONS OF M C SERIES HEATERS

	A	B	C	D	E	F	G	H	J	L	M	N
<b>M20 C</b>	630	947	800	490	370	405	438	431	215	284	393	95
<b>M30 C</b>	770	988	800	490	510	405	578	431	215	284	393	95
<b>M60 C</b>	1270	988	800	490	1010	405	1078	431	215	284	393	95

	P	Q	R	S	T	U	V	W	X	Y	Z
<b>M20 C</b>	390	435	340	600	715	563	340	-	Ø EXT 113	Ø EXT 135	300
<b>M30 C</b>	460	435	340	600	715	580	374	-	Ø EXT 113	Ø EXT 135	324
<b>M60 C</b>	468	435	340	600	715	580	870	495	Ø EXT 113	Ø EXT 135	324

Table 4 – Dimensions of M C series heaters

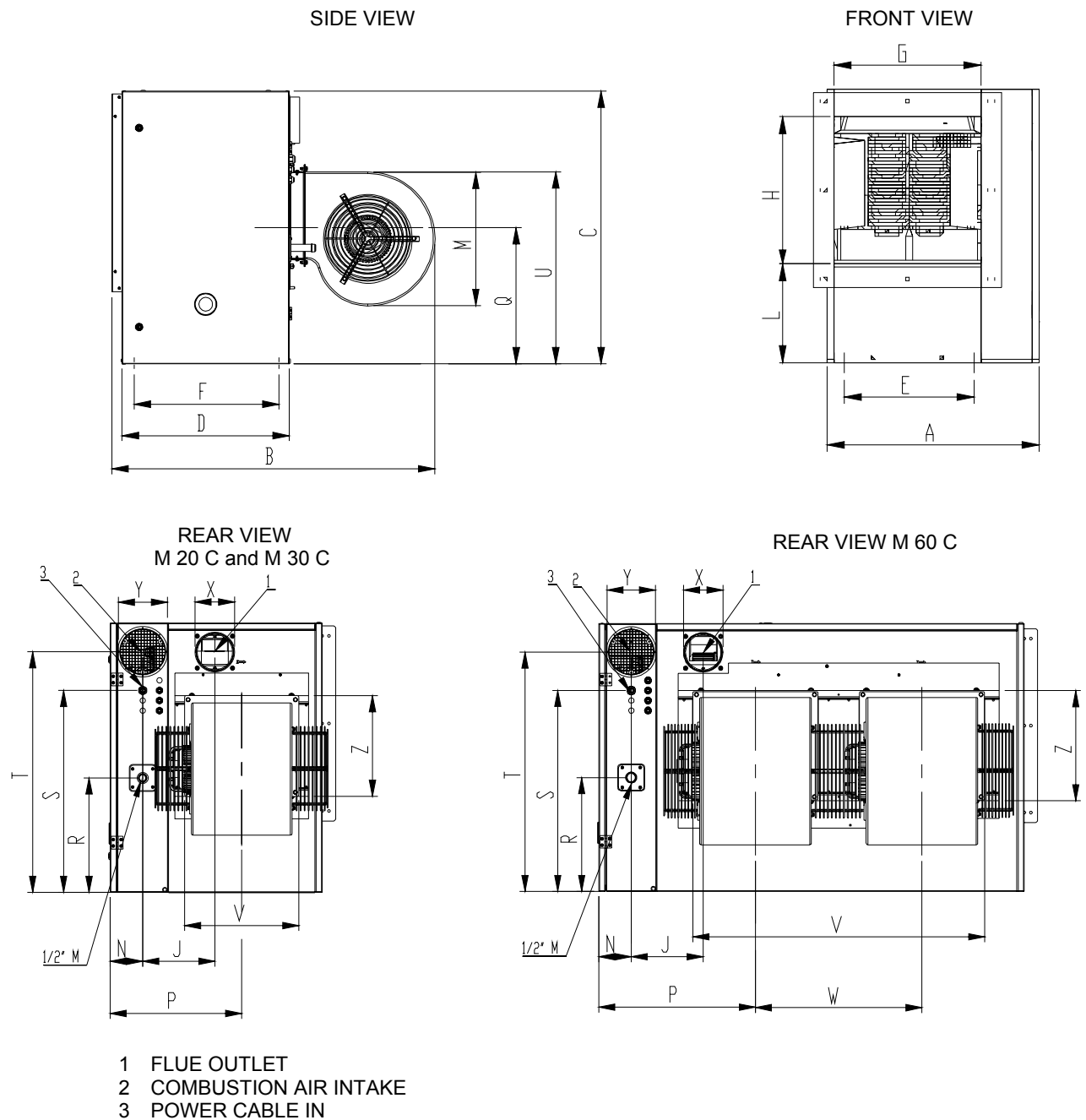

Figure 1 – Dimensions of M C series heaters



## SECTION 2: USER

In this section you will find all the indications necessary for operating the M C series heaters correctly.

### 2.1 HOW TO SWITCH THE HEATER ON AND OFF



Initial activation must be carried out by **professionally qualified personnel**.

Before starting the heater, have professionally qualified personnel check that:

- the data on the appliance's data plate correspond to mains power and gas mains data;
- the calibration is compatible with the power of the heater;
- the pipe for expelling exhaust gases is functioning correctly;
- combustion air is supplied and exhaust gases are expelled correctly in accordance with current regulations.

Operation of the M C series heater is controlled by a thermostat, available as an accessory.

#### WINTER OPERATION (HEATING)



**You will need:** the heater connected to the power and gas supply.

1. Open the gas valve.
2. Power the appliance by closing the bipolar switch.
3. Set the thermostat to maximum.
4. After a pre-wash time of approximately 30 seconds, the gas electro valve opens and the ignition electrode begins to spark.
5. When a flame is present the detector electrode stops sparking automatically, keeping the appliance operating.
6. If no flame is present, the central control unit stops the appliance and the red lock out warning light A and the reset button B lights up (see Figure 2).

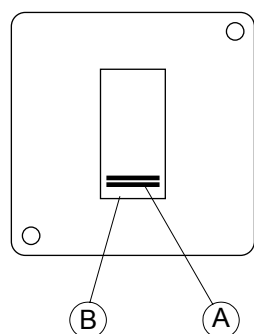

A LOCK OUT WARNING LIGHT  
B RESET BUTTON

Figure 2 – Control box supplied as standard

7. If point 6 occurs, press the reset button (B).

8. If ignition has taken place as expected, set the thermostat to the desired temperature.



If the burner is ignited after a prolonged period of inactivity or for the first time, it may be necessary to repeat the operation several times as a result of air in the pipes.

## SWITCHING OFF



**You will need:** the heater connected to the power and gas supply.

1. To switch off the appliance, set the thermostat to minimum. The burner goes out, while the fans continue to operate until the appliance has cooled down completely.



The appliance must never be switched off by removing electrical power, as this stops the fans immediately and activates the limit thermostat, which then must be reset manually.

## SUMMER OPERATION (VENTILATION)

To change from winter to summer operation (fan operation only) easily and immediately it is possible to substitute the control box supplied as standard with the O-CTR000 command (available as an accessory – see Figure 17) which has a summer/winter switch.

This command makes it possible to change from summer to winter operation by closing the gas valve by placing the summer/winter switch in the summer position (the “sun” symbol).

Alternatively, **professionally qualified personnel** can set up the appliance for summer operation as shown in “HOW TO MAKE THE ELECTRICAL CONNECTION FOR SUMMER OPERATION” on page 29.

## SEASONAL SWITCH-OFF

1. Switch off the appliance (as described in SWITCHING OFF) and wait for the fan(s) to stop.
2. Close the gas supply valve of the appliance.
3. If the VENTILATION function is not to be used, cut off electrical power to the appliance using the bipolar switch located on the power supply line.



## SECTION 3: HYDRAULIC SYSTEM INSTALLATION TECHNICIAN

In this section you will find all the indications necessary for installing the M C series heaters from a hydraulic point of view.

### 3.1 GENERAL APPLIANCE INSTALLATION PRINCIPLES

Installation must be carried out in accordance with the manufacturer's instructions by **professionally qualified personnel**;



**Professionally qualified personnel** means personnel that have specific technical expertise in the sector of heating plant components. If in doubt contact Robur S.p.A. on +39-035-888111.

Incorrect or non-compliant installation may cause damage to persons, animals or things, for which the manufacturer cannot be held responsible.

The units must be installed according to the national and international norms regarding this type of appliances and applications.

For installation purposes, the following regulations should be respected:

- The distance between the rear of the appliance and the wall should be enough to allow adequate air renewal (at least 200 mm between fan and wall). The minimum distance from the side walls is indicated in Figure 3 on page 17.
- The optimum height recommended from the ground to the base of the heater is 2.5 – 3.5 m (see Figure 3 on page 17). Installation of heaters at a height of less than 2.5 metres is not recommended.
- To obtain maximum comfort and performance from the plant, observation of the following rules is recommended:
  - make sure that the flow of air from the appliance does not strike staff directly;
  - take into account the presence of obstacles (pillars and suchlike).
- Do not install M C series heaters in greenhouses or environments with a high degree of humidity or similar weather conditions, as they have not been designed for this type of use.

### 3.2 INSTALLATION SEQUENCE

Following the installation plan, set up the gas and electricity supply lines as well as the holes for the flue pipe and combustion air intake.

1. Unpack the appliance, taking care to check that it has not been damaged during transport. Each appliance is tested in the factory before being dispatched. Therefore, if damage has occurred inform the transporter immediately.
2. Install the support bracket (available as an accessory, see ACCESSORIES on page 45), following the instructions provided on the sheet supplied with the bracket itself.
3. Fix the heater to the bracket using the screws supplied with the bracket.

4. Check that an adequate gas supply and distribution network exists. Specifically, if the appliance runs on:

**Natural gas**

the gas mains pressure must be 20 mbar (204 mm H<sub>2</sub>O) with a tolerance from 17 mbar to 25 mbar;

**L.P.G. (Propane-Butane mix)**

It is essential to fit a first-stage pressure reduction station in proximity to the liquid gas tank to reduce pressure to 1.5 bar, and a second-stage pressure reduction station for a further reduction from 1.5 bar a 30 mbar (306 mm H<sub>2</sub>O) in proximity to the heater (with a tolerance from 20 mbar to 35 mbar);

**L.P.G. (pure Propane)**

It is essential to fit a first-stage pressure reduction station in proximity to the liquid gas tank to reduce pressure to 1.5 bar, and a second-stage pressure reduction station for a further reduction from 1.5 bar a 30 mbar (377 mm H<sub>2</sub>O) in proximity to the heater (with a tolerance from 25 mbar to 45 mbar).



If in doubt regarding the composition of L.P.G. used, follow the indications for a Propane-Butane mix.

5. Connect the heater to the gas mains, fitting the gas supply pipe with a shut-off valve and a three-piece pipe union.

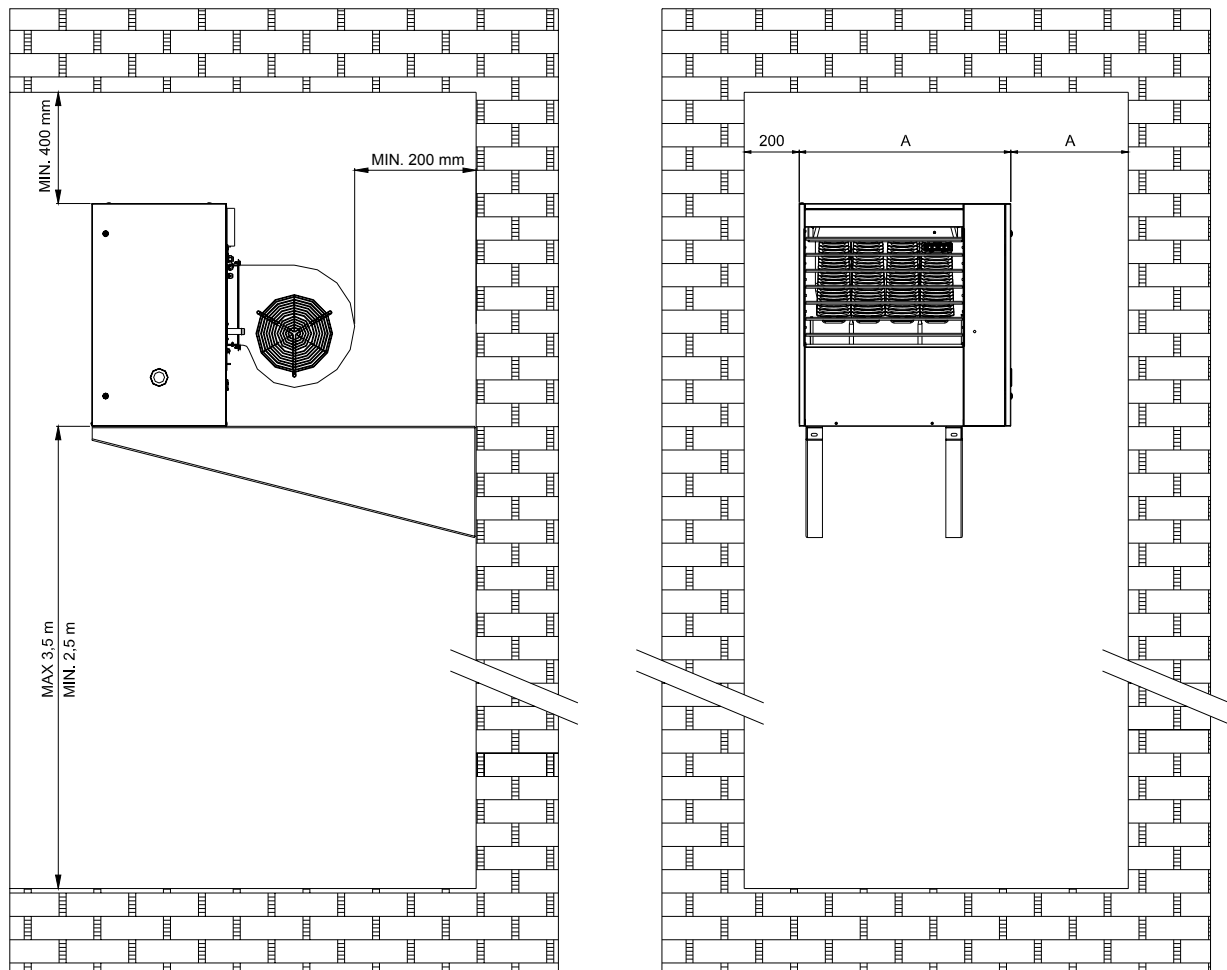

Figure 3 – Clearances

### 3.3 SIZING OF COMBUSTION AIR AND FLUE PIPES

M C series warm air heaters are approved for installation in one of the following ways:

- **C<sub>12</sub>** type installation: expulsion of combustion products and intake of combustion air are wall-based, via separate (see Figure 4 on page 18) or coaxial (see Figure 5 on page 18 and Figure 6 on page 19) ducts. In this way the appliance is sealed off from the room in which it is installed.
- **C<sub>32</sub>** type installation: expulsion of combustion products and intake of combustion air are roof-based, via separate or coaxial ducts (see Figure 7 on page 19). In this way the appliance is sealed off from the room in which it is installed.
- **B<sub>22</sub>** type installation: intake of combustion air takes place in the room and combustion products are expelled outside via a specific duct, which may be either horizontal or vertical. In this way the appliance is not sealed off from the room (see Figure 8 on page 20 and Figure 9 on page 20).

C12 TYPE INSTALLATION WITH SEPARATE WALL DUCTS

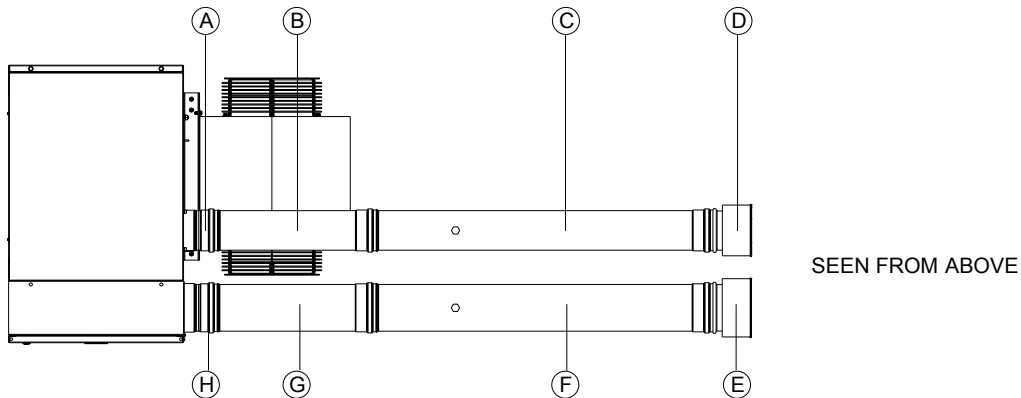

REF.	CODE	Q.TY	DESCRIPTION
A	O-TBO011	1	Flue pipe adaptor, Ø 110 mm
B	O-TBO003	1	Ø 110 mm pipe, length = 0.5 m
C	O-TBO005	1	Ø 110 mm pipe, length = 1 m with intake element
D	O-12114330	1	Wall-mounted wind-protected terminal in steel, Ø 110 mm
E	O-12114340	1	Wall-mounted wind-protected terminal in steel, Ø 130 mm
F	O-TBO006	1	Ø 130 mm pipe, length = 1 m with intake element
G	O-TBO004	1	Ø 130 mm pipe, length = 0.5 m
H	O-TBO012	1	Flue pipe adapter, Ø 130 mm
-	O-FSC000	3	Pipe clamp, Ø 110 mm
-	O-FSC001	3	Pipe clamp, Ø 130 mm
	O-STF009	1	Support bracket

Figure 4 – C12 type installation with separate wall-mounted ducts

M 20 C and M 30 C:  
C12 TYPE INSTALLATION WITH COAXIAL WALL DUCTS

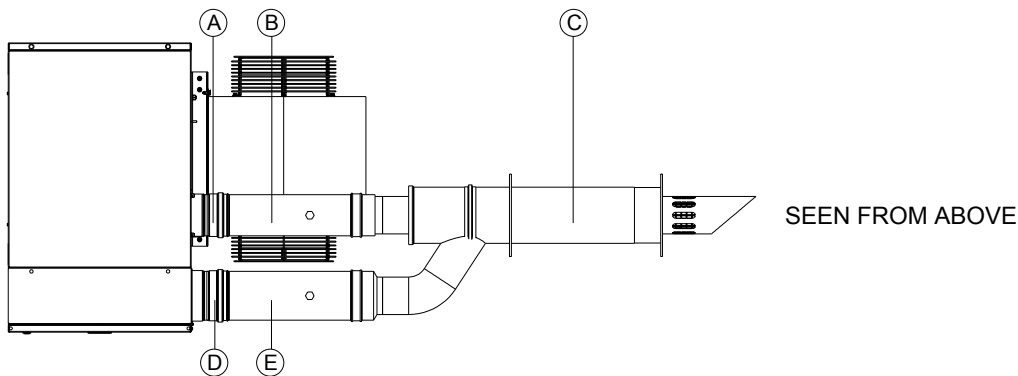

REF.	CODE	Q.TY	DESCRIPTION
A	O-TBO011	1	Flue pipe adaptor, Ø 110 mm
B	O-TBO005	1	Ø 110 mm pipe, length = 1 m with intake element
C	O-SCR000	1	Wall-mounted coaxial flue pipe, Ø 150 mm
D	O-TBO012	1	Flue pipe adapter, Ø 130 mm
E	O-TBO006	1	Ø 130 mm pipe, length = 1 m with intake element
-	O-FSC000	2	Pipe clamp, Ø 110 mm
-	O-FSC001	2	Pipe clamp, Ø 130 mm
	O-STF009	1	Support bracket

Figure 5 – M 20 C and M 30 C: C12 type installation with coaxial wall-mounted duct (O-SCR000)



M 60 C:  
C12 TYPE INSTALLATION WITH COAXIAL WALL DUCT

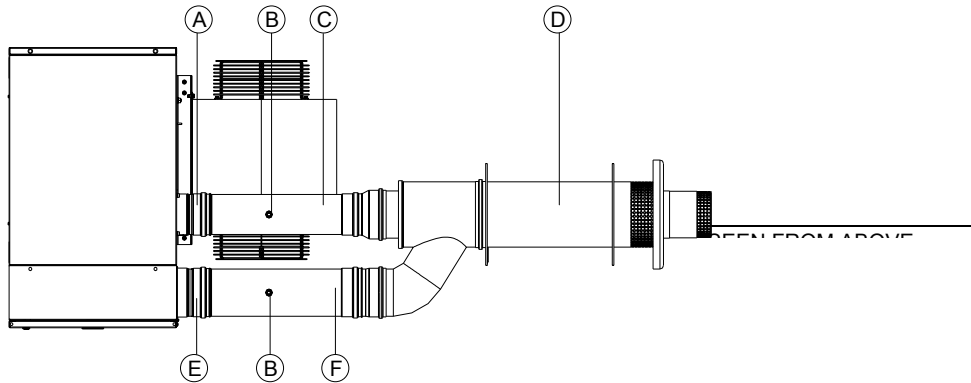

REF.	CODE	Q.TY	DESCRIPTION
A	O-TBO011	1	Flue pipe adaptor, Ø 110 mm
B	O-TPP004	2	Intake plug on flue pipes
C	O-TBO003	1	Ø 110 mm pipe, length = 0.5 m
D	O-SCR001	1	Wall-mounted coaxial flue pipe, Ø 180 mm (including pipe adaptors)
E	O-TBO012	1	Flue pipe adapter, Ø 130 mm
F	O-TBO004	1	Ø 130 mm pipe, length = 0.5 m
-	O-FSC000	2	Pipe clamp, Ø 110 mm
-	O-FSC001	2	Pipe clamp, Ø 130 mm
	O-STF009	1	Support bracket

Figure 6 – M 60: C12 type installation with wall-mounted coaxial duct (OSCR001)

TYPE C32 INSTALLATION WITH ROOF-MOUNTED COAXIAL DUCT

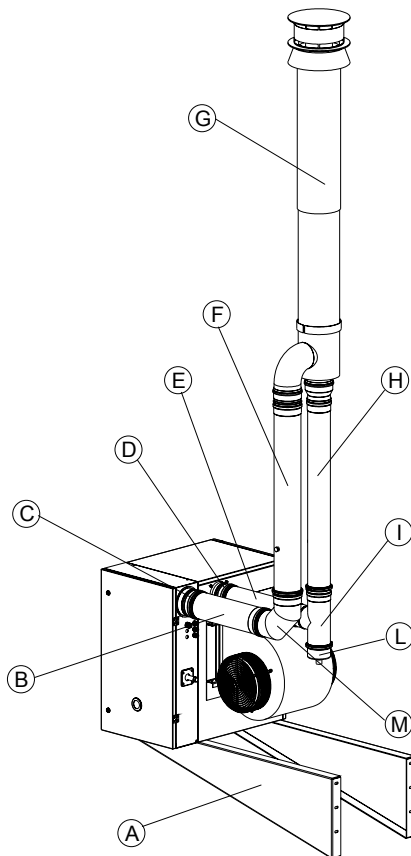

REF.	CODE	Q.TY	DESCRIPTION
A	O-STF009	1	Support bracket
B	O-TBO004	2	Ø 130 mm pipe, length = 0.5 m
C	O-TBO012	1	Flue pipe adapter, Ø 130 mm
D	O-TBO011	1	Flue pipe adapter, Ø 110 mm
E	O-TBO003	1	Ø 110 mm pipe, length = 0.5 m
F	O-TBO006	1	Ø 130 mm pipe, length = 1 m with intake element
G	O-SCR002	1	Wall-mounted coaxial flue pipe, Ø 180 mm (including pipe adaptors)
H	O-TBO005	1	Ø 110 mm pipe, length = 1 m with intake element
I	O-RCC000	1	T connector, Ø 110 mm
L	O-TPP000	1	Plug for T connector, Ø 110 mm for condensate drainage
M	O-CRV002	1	90° elbow, Ø 130 mm
-	O-FSC000	5	Pipe clamp, Ø 110 mm
-	O-FSC001	4	Pipe clamp, Ø 130 mm

Figure 7 – C32 type installation with roof-mounted coaxial duct (O-SCR002)

B22 TYPE INSTALLATION WITH WALL-MOUNTED EXHAUST DUCT

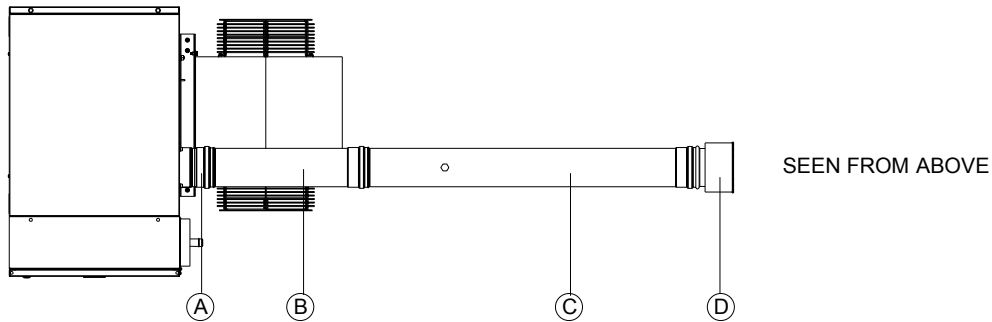

REF.	CODE	Q.TY	DESCRIPTION
A	O-TBO011	1	Flue pipe adaptor, Ø 110 mm
B	O-TBO003	1	Ø 110 mm pipe, length = 0.5 m
C	O-TBO005	1	Ø 110 mm pipe, length = 1 m with intake element
D	O-12114330	1	Wall-mounted wind-protected terminal in steel, Ø 110 mm
-	O-FSC000	3	Pipe clamps, Ø 110 mm
	O-STF009	1	Support bracket

Figure 8 – B22 type installation with wall-mounted flue pipe

B22 TYPE INSTALLATION WITH ROOF-MOUNTED FLUE PIPE

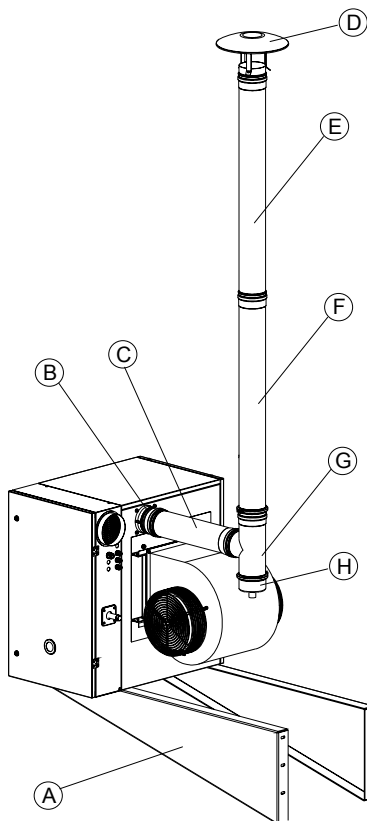

REF.	CODE	Q.TY	DESCRIPTION
A	O-STF009	1	Support bracket
B	O-TBO011	1	Flue pipe adapter, Ø 110 mm
C	O-TBO003	1	Ø 110 mm pipe, length = 0.5 m
D	O-TRM000	1	Roof terminal, Ø 110
E	O-TBO001	1	Ø 110 mm pipe, length = 1 m
F	O-TBO005	1	Ø 110 mm pipe, length = 1 m with intake element
G	O-RCC000	1	T connector, Ø 110 mm
H	O-TPP000	1	Plug for T connector, Ø 110 mm for condensate drainage
-	O-FSC000	6	Pipe clamps, Ø 110 mm

Figure 9 – B22 type installation with roof-mounted flue pipe



Ambient ventilation air can be taken wholly or partially from the outside or wholly or partially from the inside of the room (for further information see “AIR CHANGES” on page 25).

It is necessary to use ducts approved for the type of installation to be carried out. ROBUR S.p.A. can supply to order rigid pipes, coaxial ducts and approved terminals.

In order to size the system it is necessary to calculate the overall pressure drop generated by the system itself.

The total pressure drop admitted by the system of pipes depends on the model of appliance (Table 5 on page 23).

Pressure drops of the flue pipes, air pipes and coaxial pipes supplied by ROBUR are given in Table 6 and Table 7 on page 23.

The pressure drops associated with external terminals can be ignored, as they are extremely low.

In the project stage it must be ensured that the sum of the pressure drops of the system of pipes is lower than the maximum pressure drop admitted by the appliance and higher than the minimum pressure drop admitted (see Table 5). In the following pages an example of how to carry out the calculation of the pressure drop is provided.

- ☞ If horizontal flue pipes over 1 metre long are installed, in order to prevent the potential formation of drops of condensate reaching the appliance it is necessary to install the flue pipe with a counter-gradient of 2 or 3 cm for each metre of its length (see Figure 10). In addition, in order to install the external flue terminals and combustion air intake terminals correctly, follow the instructions given in Figure 13.

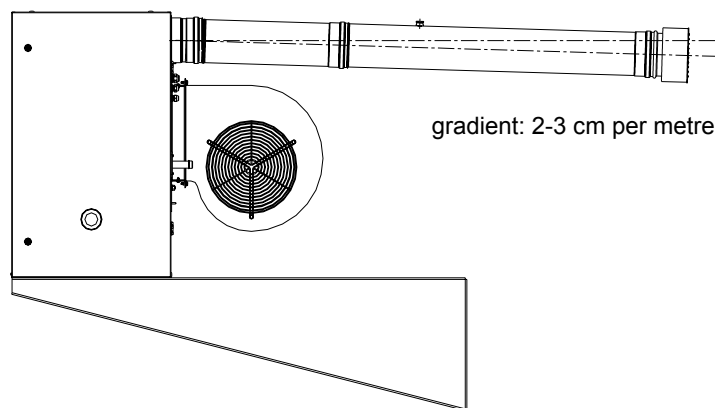

**Figure 10** – Horizontal pipe gradient

- ☞ For vertical flue pipes, in order to prevent possible drops of condensate reaching the flue fan, it is necessary to fit a “T”-shaped element at the bottom of the vertical flue pipe for the collection of condensate (Figure 7 on page 19). If a mixing chamber is installed (available as an accessory – see ACCESSORIES on page 45), in order that the condensate drain does not interfere with the mixing chamber the drain must be fitted as indicated in Figure 11.

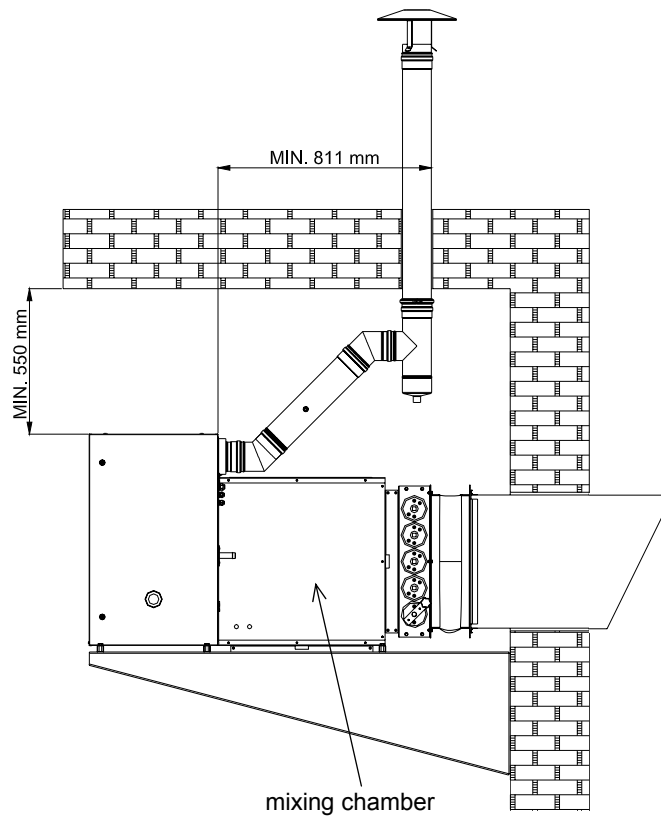

**Figure 11** – Flue pipe set-up if a mixing chamber is used

If a mixing chamber is installed (available as an accessory – see ACCESSORIES on page 45), in order to prevent combustion gases coming into contact with the heated environment it is important to avoid positioning the flue pipe outlet within the clearance area indicated in Figure 12.

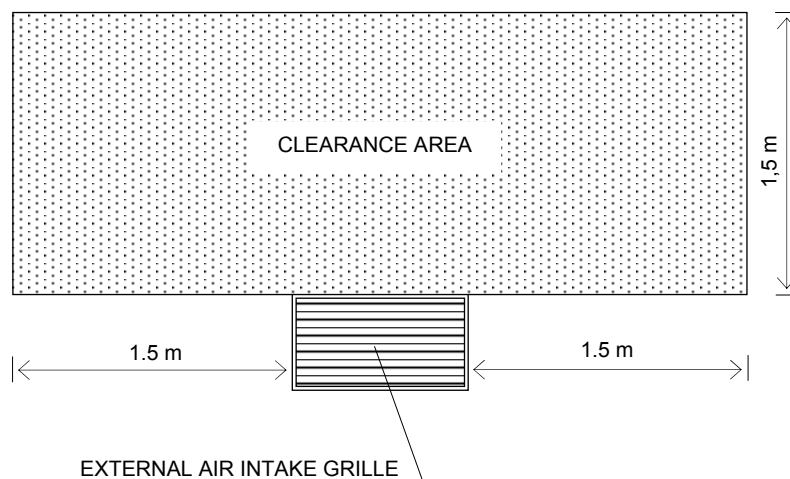

**ATTENTION:** DO NOT POSITION THE EXHAUST OUTLET IN THE CLEARANCE AREA INDICATED

**Figure 12** – Clearance area for flue pipe outlet of M C series heaters with mixing chamber



MODEL	AIR DIAPHRAGM		FLUE DIAPHRAGM		PRESSURE DROP ADMISSIBLE (PA)	
	HEIGHT (MM)	CODE	HEIGHT (MM)	CODE	MAXIMUM	MINIMUM
M20 C	----	----	60	019	40	----
M30 C	84	007	----	----	35	23
	84	007	55	013	25	----
M60 C	----	----	----	----	69	45
	----	----	45	012	46	22
	----	----	55	013	21	----

**Table 5** – Pressure drop admissible according to the model and diaphragm fitted

MODEL	AIR DIAPHRAGM		FLUE DIAPHRAGM		PRESSURE DROP, FLUE PIPE (Pa/m)		PRESSURE DROP, AIR PIPE (Pa/m)	
	H (mm)	CODE	H (mm)	CODE	Ø 110	Ø 130	Ø 110	Ø 130
M20 C	----	----	60	019	0.46	0.20	0.17	0.07
M30 C	84	007	----	----	1.21	0.53	0.45	0.20
	84	007	55	013	1.11	0.49	0.41	0.18
M60 C	----	----	----	----	4.82	2.12	1.49	0.66
	----	----	45	012	5,49	2.42	1.73	0.76
	----	----	55	013	5,16	2.27	1.66	0.73

**N.R. = DIAMETER NOT RECOMMENDED**

**Table 6** – Pressure drop, air pipes and flue pipes



For each 90° elbow calculate an increase in overall length of 1.5 metres.  
 For each “T” element calculate an increase in overall length of 2.0 metres.  
 For each 45° elbow calculate an increase in overall length of 0.75 metres.

MODEL	AIR DIAPHRAGM		FLUE DIAPHRAGM		PRESSURE DROP, COAXIAL DUCT Ø 100 FOR M20 C & M30 C (Pa)*		PRESSURE DROP, COAXIAL DUCT Ø 130 FOR ALL MODELS (Pa)*	
	H (mm)	CODE	H (mm)	CODE	WALL OUTLET (O-SCR000)	WALL OUTLET (O-SCR001)	ROOF OUTLET (O-SCR002)	
M20 C	----	----	60	019	5.8	2.0	2.2	
M30 C	84	007	----	----	18.0	5.0	5.6	
	84	007	55	013	18.0	5.0	5.6	
M60 C	----	----	----	----	N.R.	29.5	33.1	
	----	----	45	012	N.R.	29.5	33.1	
	----	----	55	013	N.R.	N.R.	N.R.	

**N.R.= DIAMETER NOT RECOMMENDED**

**\* PRESSURE DROPS TO BE CALCULATED INCLUDING CONNECTORS**

**Table 7** – Pressure drop, coaxial ducts

### EXAMPLE OF CALCULATION

Suppose that we are installing an M30 C heater with a flue diaphragm which is 55 cm in height. The air/flue system is to be built as follows:

- 3 metres of flue pipe, Ø 110
- 2 90° elbows, Ø 110, on flue pipe
- 2 metres of air pipe, Ø 130

It is therefore possible to make a checking calculation, remembering that the maximum admissible pressure drop is 25 Pa (see Table 5).

	Quantity		Pressure drop				
flue pipe Ø 110	3 m	x	1.11 Pa	=	3.33 Pa	+	
90° elbows	2 x 1.5 m	x	1.11 Pa	=	3.33 Pa	+	
air pipe, Ø 130	2 m	x	0.18 Pa	=	0.36 Pa	=	
Total pressure drop					7.02 Pa		

The total pressure drop of the system of pipes (7.02 Pa) is LOWER than the maximum admissible pressure drop (25 Pa). Therefore the installation is PERMITTED.



If the total length of the system of pipes is over 16 metres, contact Robur Pre-Sales Service on 035-888111.

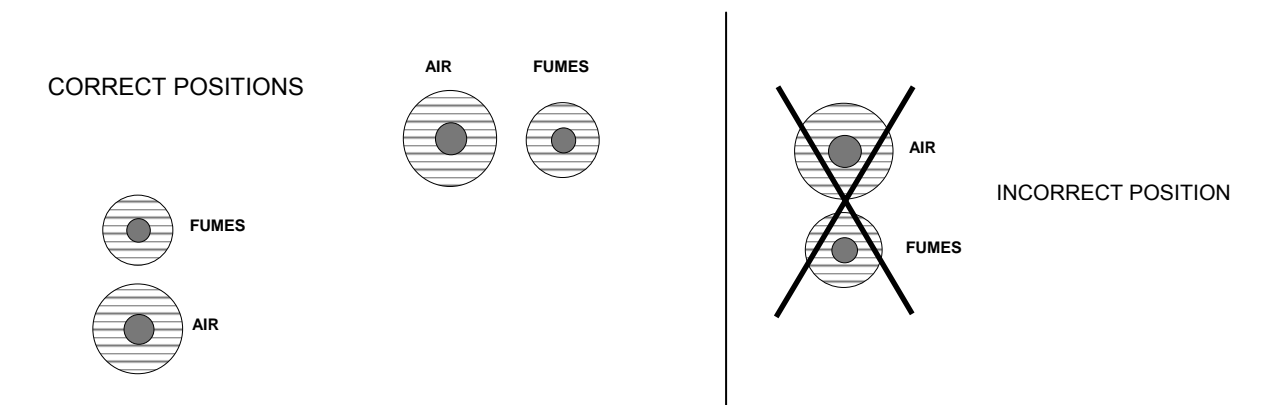

Figure 13 – Position of wall terminals

### 3.4 INSTALLATION OF FLUE DIAPHRAGM

One or more flue diaphragms are supplied as standard with the M30 C and M60 C heaters.

To fit the diaphragm, follow the instructions given below.



**You will need:** the heater disconnected from the power supply.

1. Open the electrical panel door.
2. Unscrew the screw which holds the cover in place (see Figure 14).
3. Remove the cover.
4. Unscrew the two lower screws which hold the flue fan and loosen the two upper screws.



5. Insert the flue diaphragm between the flue outlet flange and the flue fan flange, so that the holes in the diaphragm are turned downwards.
6. Line up the holes of the diaphragm with the lower holes.
7. Retighten the upper and lower screws that fix the flue fan.
8. Reposition the cover and retighten the fixing screw.

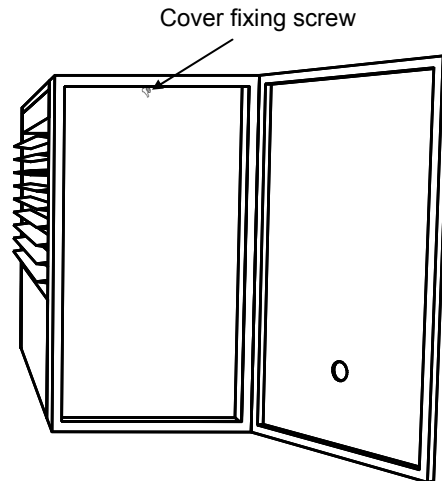

Figure 14 – Cover fixing screws

### 3.5 AIR CHANGES

Intake of ventilation air can occur in one of the following ways:

- intake of indoor air only;
- partial or total intake of outdoor air to renew air in the room.

In the latter case (partial or total intake of outdoor air) it is necessary to use some components available as accessories (for further information see “ACCESSORIES”) and make sure that the sum of pressure drops of the components fitted (see Table 8) and of the pressure drop of the warm air distribution ducting does not exceed the pressure head (see Table 3).

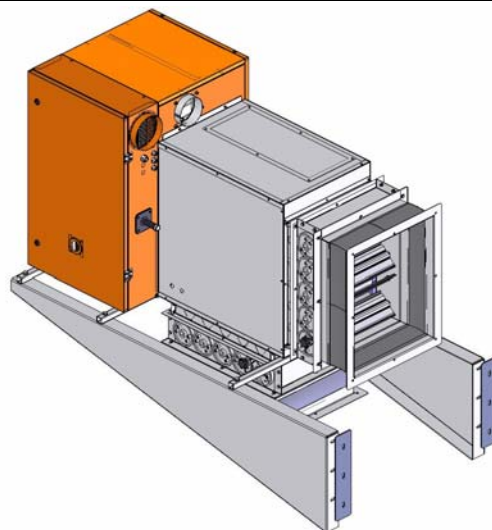

Figure 15 – M C installation with accessories for partial or total intake of outdoor air

COMPONENT	CHARACTERISTICS	PRESSURE DROPS (Pa)
MIXING CHAMBERS (ALL MODELS)	FITTED WITH ONLY REAR OPENING CLEARS	0
AIR FILTER FOR M 20 C	FILTER CLASS G3 (EN 779)	35
AIR FILTER FOR M 30 C		50
AIR FILTER FOR M 60 C		50
ADJUSTMENT DAMPERS (ALL MODELS)	DAMPERS COMPLETELY OPEN. IF AIR INTAKE IS PARTLY FROM OUTSIDE AND PARTLY FROM INSIDE, A SECOND DAMPER IS REQUIRED TO COMPENSATE AIR FLOW	10

Table 8 – Pressure drops of aeration components

### 3.6 WALL INSTALLATION WITH SUPPORT BRACKET

For the fitting of the Robur M C series heaters, an easy-to-fit support bracket is supplied (see ACCESSORIES on page 45). If this accessory is not used, refer to Figure 16 which indicates the minimum dimensions of the bracket for standard installations (without mixing chamber). To fix the heater onto the support brackets, use 4 M10 bolts.

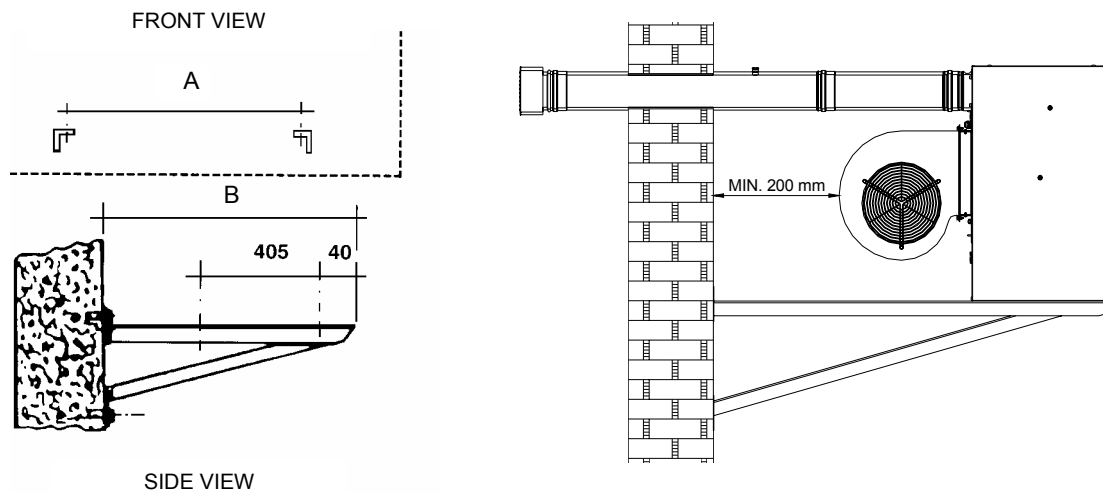

Figure 16

MODEL	M20 C	M30 C	M60 C
A	370	510	1010
B	1115	1160	



## SECTION 4: ELECTRICAL SYSTEM INSTALLATION TECHNICIAN

In this section you will find all the indications necessary for connecting the MC series heaters electrically.

### 4.1 HOW TO CONNECT THE HEATER TO THE POWER SUPPLY



**You will need:** the heater installed.



Electrical connections must be made by **professionally qualified personnel**. In any case, before making the electrical connections, make sure that the wires are not live.

1. Make sure that the power supply is 230V - 50Hz, single phase.
2. Make the connection to the power supply, following the assembly wiring diagram (see Figure 18 on page 30) and using a type H05 VVF 3x1.5 mm<sup>2</sup> cable with a maximum external diameter 8.4 mm.
3. Make the electrical connection so that the ground wire is longer than the live wires. In this way it will be the last cable to be disconnected if the power cable is accidentally pulled, thus ensuring that the appliance remains grounded.



The electrical safety of the appliance is achieved only when it is connected to efficient safety regulations. Do not use gas pipes to ground electrical appliances.

4. The heater must be connected to the power supply via a bipolar switch with a minimum contact gap of 3 mm. *A bipolar switch is defined as one which can be opened on both phase and neutral.* This means that when it is open both contacts are open.

### 4.2 HOW TO INSTALL THE CONTROL BOX



**You will need:** the heater installed.





Electrical connections must be made by **professionally qualified personnel**. In any case, before making the electrical connections, make sure that the wires are not live.

For the installation of the control box, supplied as standard with the heater, proceed as follows:

1. Locate the position where the control box is to be installed.
2. Drill a hole in the wall in line with the fixing points of the control box.
3. Fix the control box with two screws and rawl plugs.

4. Connect the heater to the power supply and switch it on.
5. Close the gas valve and check that after a few seconds the arrest warning light A comes on (see Figure 2).
6. Open the gas valve again, push the reset button B (see Figure 2) and check that the arrest warning light switches off and that the heater starts up again.

 The control cables (in particular the one connecting the heater to the control box) **must be protected from interference produced by the power cables**. This protection can be obtained for example by shielding the cables or by running them through channels which are separate from those of the power cables.

 The maximum length of the cable connecting the heater to the control box is 20 metres.

### 4.3 HOW TO CONNECT THE THERMOSTAT TO THE HEATER

For the operation of the heater it must be connected to an ambient thermostat (available as an accessory). For the installation of the ambient thermostat, follow the instructions below.



**You will need:** the heater installed.



Electrical connections must be made by **professionally qualified personnel**. In any case, before making the electrical connections, make sure that the wires are not live.

1. Locate the position where the ambient thermostat is to be installed, if possible approximately 1.5 metres from the floor, away from draughts, direct sunlight, and direct heating sources (light bulbs, flows of hot air from the appliance itself, etc.) and if possible NOT on outer walls, in order not to falsify the temperature readings and therefore the operation of the appliance. **IN THIS WAY THE APPLIANCE WILL BE PREVENTED FROM STARTING AND STOPPING WHEN NOT DESIRED, THUS GUARANTEEING OPTIMAL COMFORT LEVELS IN THE ROOM.** If this is not possible, shield the ambient thermostat by placing a sheet of insulating material (e.g. cork, polystyrene, etc.) between it and the wall.
2. Fix the ambient thermostat to the wall.
3. Connect the ambient thermostat to the terminal board of the heater following the instructions provided in Figure 18 on page 30.



## 4.4 HOW TO MAKE THE ELECTRICAL CONNECTION FOR SUMMER OPERATION

To change from winter to summer operation (fan operation only), follow the instructions below.



**You will need:** the heater connected to the power and gas supply.

1. Close the gas valve and disconnect the appliance from the power supply.
2. Access the instrument panel and move the "electrical bridge" from the WINTER position (terminals 1-3) to the SUMMER position (terminals 1-2) (see Figure 18 on page 30).
3. Power the appliance: in this way only the fan(s) will operate, providing a pleasant movement of air in the room.
4. At the end of the summer season, to change from summer to winter operation, it is necessary to move the "electrical bridge" from the SUMMER position (terminals 1-2) to the WINTER position (terminals 1-3).

Alternatively, rather than performing the operations described above, to change easily and immediately from summer to winter operation and vice versa, it is possible to replace the supplied control box with a command equipped with a summer/winter button (available as an accessory - O-CTR000 - see Figure 17).

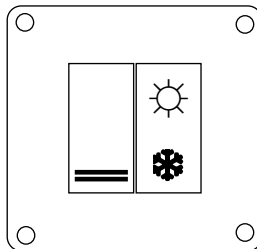
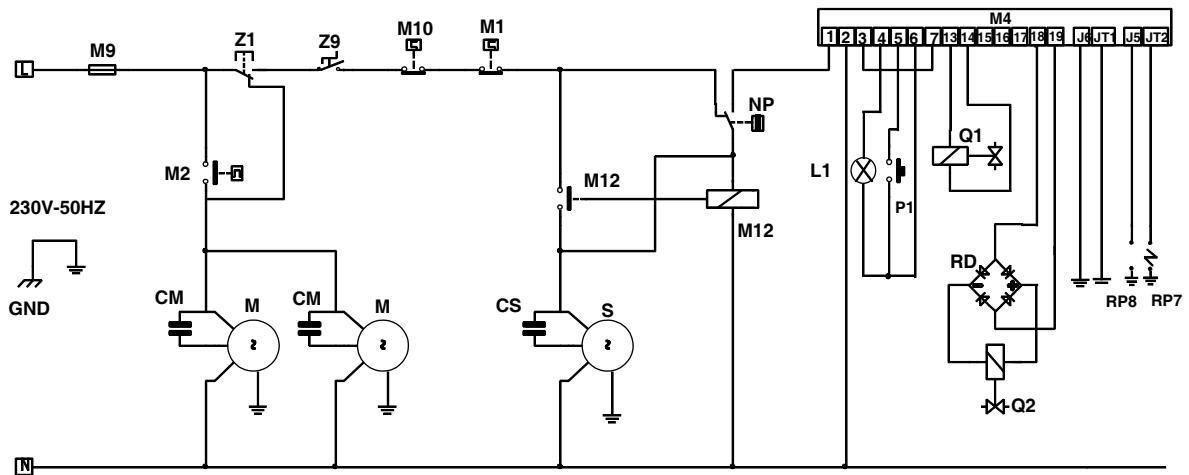

Figure 17 – Control box available as an accessory (O-CTR000).





## 4.6 OPERATION WIRING DIAGRAM



**KEY**

- |     |  |     |  |
|-----|--|-----|--|
| CM  | fan condenser                            | Q1  | gas electrovalve                             |
| CS  | flue fan condenser                       | Q2  | soft opening modulator<br>(for M 60 C model) |
| L1  | arrest warning light                     | RD  | rectifier bridge<br>(for M 60 C model)       |
| M   | fan motor<br>(2 motors for M 60 C model) | RP7 | ignition electrode                           |
| M1  | limit thermostat                         | RP8 | detector electrode                           |
| M10 | safety thermostat                        | S   | flue fan motor                               |
| M12 | manostat control relay                   | Z1  | summer/winter switch (optional)              |
| M2  | ventilation thermostat                   | Z9  | ambient thermostat (optional)                |
| M4  | flame control unit                       |     |  |
| M9  | 6.3 A fuse (M20 and M30), 10 A (M60)     |     |  |
| NP  | differential manostat                    |     |  |
| P1  | reset button                             |     |  |

Figure 19 – Operation wiring diagram for M C series heaters

## 4.7 ELECTRICAL CONNECTION DIAGRAM FOR SUMMER/WINTER SWITCH AND PROGRAMMABLE TIMER

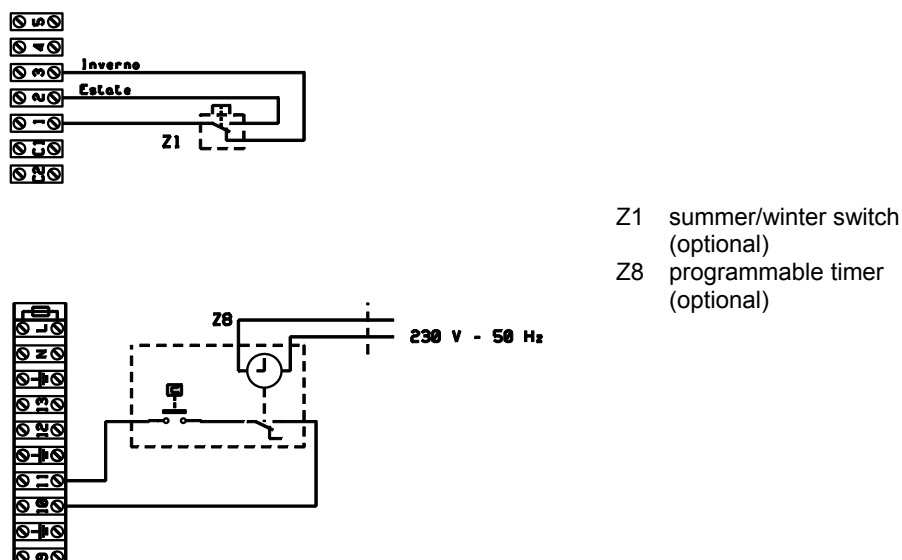

- |    |                                    |
|----|------------------------------------|
| Z1 | summer/winter switch<br>(optional) |
| Z8 | programmable timer<br>(optional)   |

Figure 20 – Wiring diagram for summer/winter switch and programmable timer

## 4.8 WIRING DIAGRAM FOR CONNECTION OF SEVERAL HEATERS

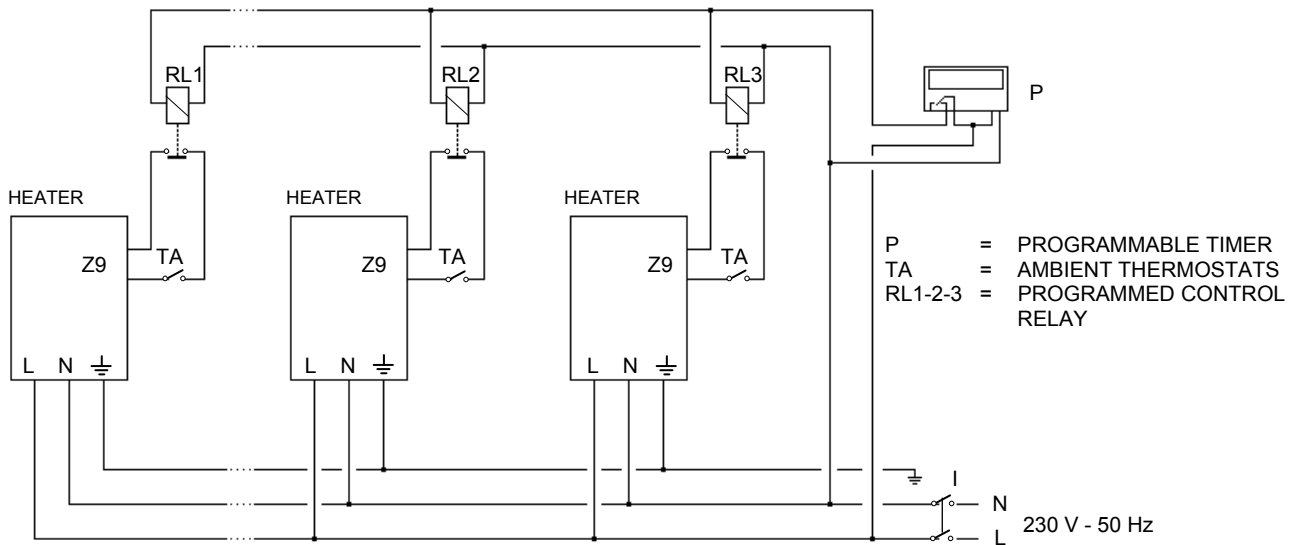

Figure 21 - Wiring diagram for several heaters with a single programmable timer and several ambient thermostats

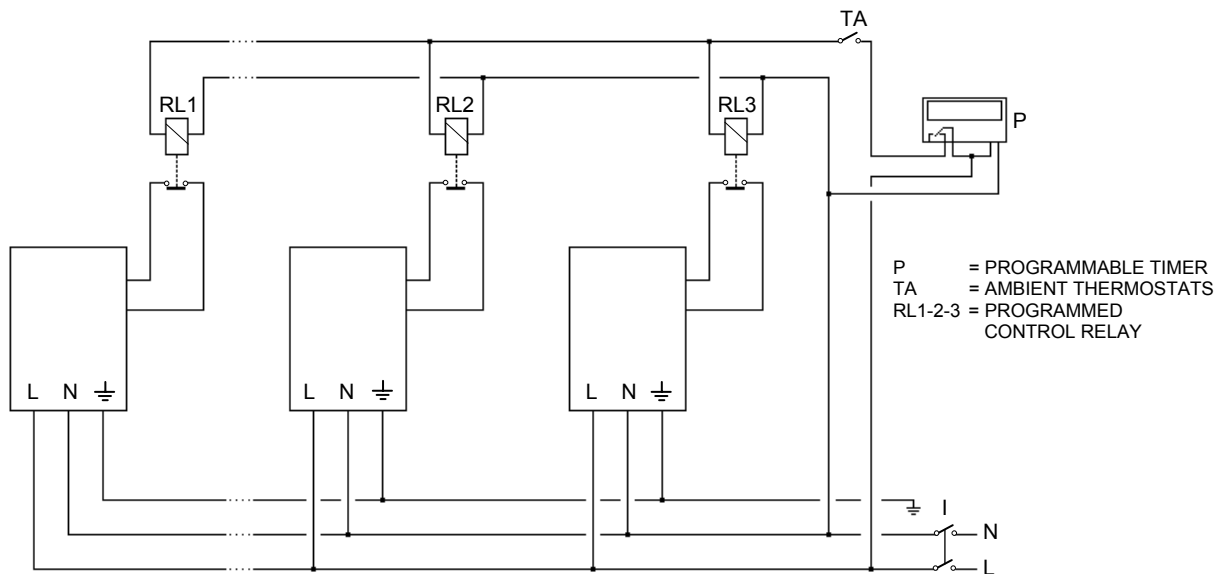
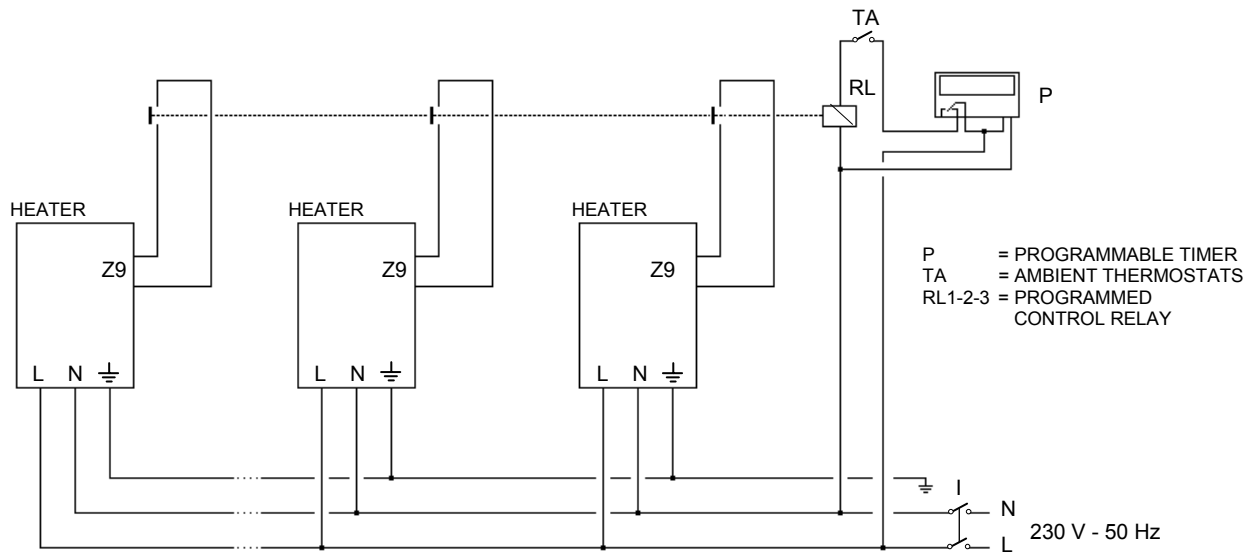

Figure 22 - Wiring diagram for several heaters with a single programmable timer and a single ambient thermostat (solution with several relays)



**Figure 23** - Wiring diagram for several heaters with a single programmable timer and a single ambient thermostat (solution with a single relay)





## SECTION 5: TECHNICAL ASSISTANCE AND MAINTENANCE

In this section you will find all the indications necessary for service technicians to carry out regulation of the gas valve and change of gas type, as well as some indications regarding maintenance.

### 5.1 HOW TO REGULATE THE GAS VALVE

For the proper operation of the M C series heaters, the calibration values of the gas valve must be the same as those given in Table 9 or in Table 10. The appliance leaves the factory with the gas valve already calibrated. If regulation is necessary, proceed as follows.



Regulation of the gas valve must be carried out by **professionally qualified personnel**.

#### OPERATION WITH NATURAL GAS



**You will need:** the heater installed and connected to the power and gas supply.

1. Connect a pressure gauge to the pressure intake P1 (see Figure 26).
2. Switch on the heater.
3. Remove the protective cover and turn the adjustment screw (see A in Figure 24 or B in Figure 25) clockwise to increase pressure or anticlockwise to reduce it, until the pressure indicated in Table 9 is reached.
4. Switch the heater off and on and check that the pressure to the burner has stabilised. If necessary adjust it again.
5. In the case of M 60 C heaters, proceed with regulation of soft opening (see "REGULATION OF SOFT OPENING (FOR M 60 C HEATERS)").



After regulation has been completed, the adjustment screw of the gas valve must be sealed.

PRESSURES AT THE BURNER OF SERIES M C APPLIANCES FUELLED BY NATURAL GAS (G20) (GAS SUPPLY PRESSURE 20 mbar)				
		M 20 C	M 30 C	M 60 C
PRESSURE at the BURNER	(mbar)	11.8	7.8	8.0
	(mmH <sub>2</sub> O)	120	80	82

**Table 9** – Pressures at the burners for M C series appliances fuelled by natural gas (G20)

## OPERATION WITH L.P.G. GAS



**You will need:** the heater installed and connected to the power and gas supply.

Check that the adjustment screw, B, is tightened (see Figure 24 or Figure 25). If it is not, tighten it completely. Pressure at the burner is now directly in relation to the mains gas supply pressure; therefore ensure that mains pressure is 30 mbar (for G30 gas) or 37 mbar (for G31 gas). Mains gas pressure can be reduced by means of a suitable first-stage pressure reduction station, in proximity to the liquid gas tank, in order to reduce the pressure to 1.5 bar, and a second-stage pressure reduction station, from 1.5 bar to 0.03 or 0.037 bar, in proximity to the heater but also outside the building.

In the case of M 60 C heaters, proceed with the regulation of soft opening (see “REGULATION OF SOFT OPENING (FOR M 60 C HEATERS)”).

PRESSURES AT THE BURNER FOR SERIES M C APPLIANCES FUELLED BY L.P.G. (G30 – G31) (GAS SUPPLY PRESSURE 30 – 37 mbar)				
		M 20 C	M 30 C	M 60 C
PRESSURE at the BURNER	(mbar)	28.5	28	27.5
	(mmH <sub>2</sub> O)	291	286	281

**Table 10** – Pressures at the burner for M C series appliances fuelled by L.P.G. (G30 – G31)

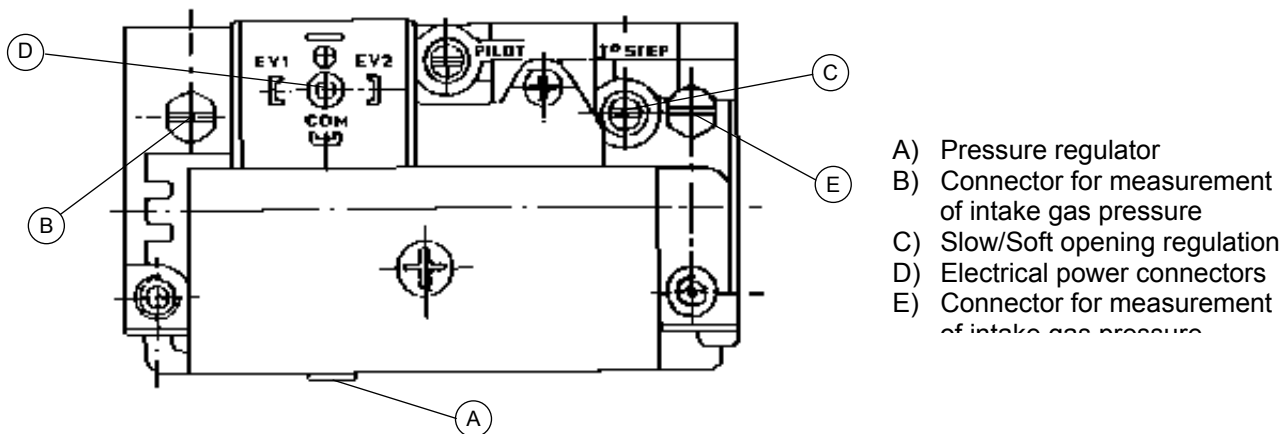

**Figure 24** – Sit 830 Tandem Valve (for M 20 C and M 30 C)

### REGULATION OF SOFT OPENING (FOR M 60 C HEATERS)

To regulate soft opening, proceed as follows (see Figure 25):

1. Disconnect power from the SMD coil (D). The heater will adjust itself to the soft opening pressure.
2. Keeping the nut B fixed, regulate the soft opening pressure to the value indicated in Table 11 by means of screw A (using a screwdriver).
3. Replace the plastic cover C.
4. Reconnect the SMD coil (D).



After regulation has been completed, the adjustment screw of the gas valve must be sealed.

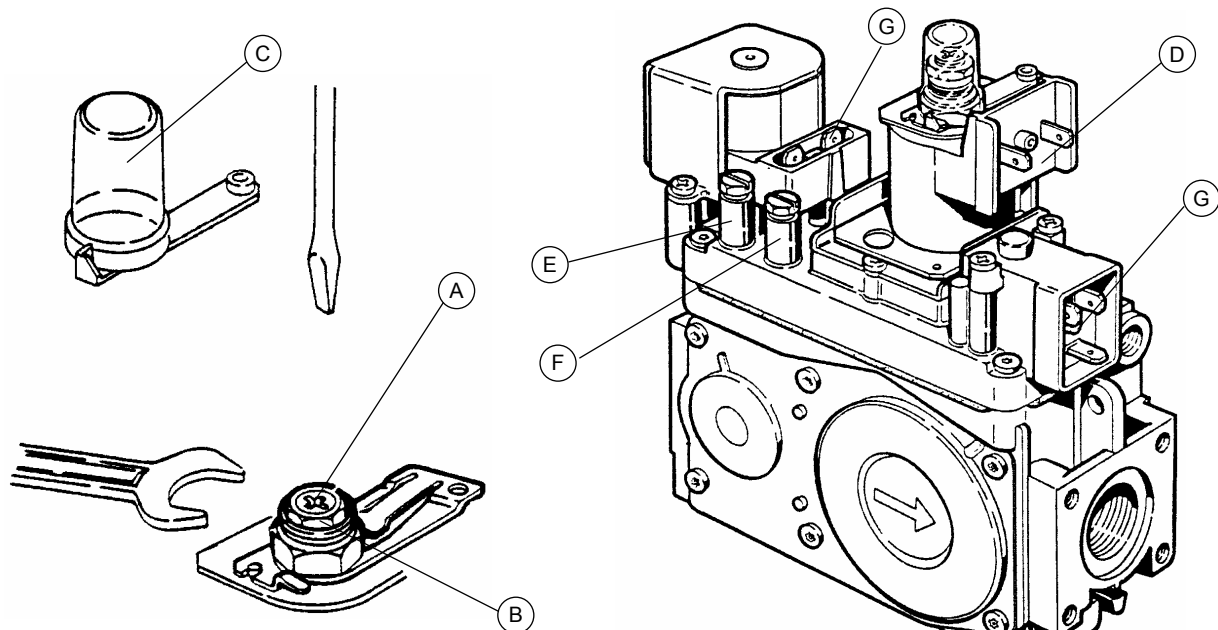

- A) Soft opening adjustment
- B) Nut for regulation of pressure at the burner
- C) Adjustment screw protection
- D) Electrical connector SMD soft opening coil
- E) Connector for measurement of intake gas pressure
- F) Connector for measurement of outlet gas pressure
- G) Electrical power connectors

Figure 25 – Sit 826 Tandem Valve (for M 60 C)

PRESSURES AT THE BURNER FOR SOFT OPENING		
	M 60 C	
	NATURAL GAS (G20)	L.P.G. (G30 – G31)
PRESSURE at the BURNER (mbar)	3.9	14.1
(mmH <sub>2</sub> O)	40	143

Table 11 – Pressures at the burner for soft opening on M 60 C series appliances

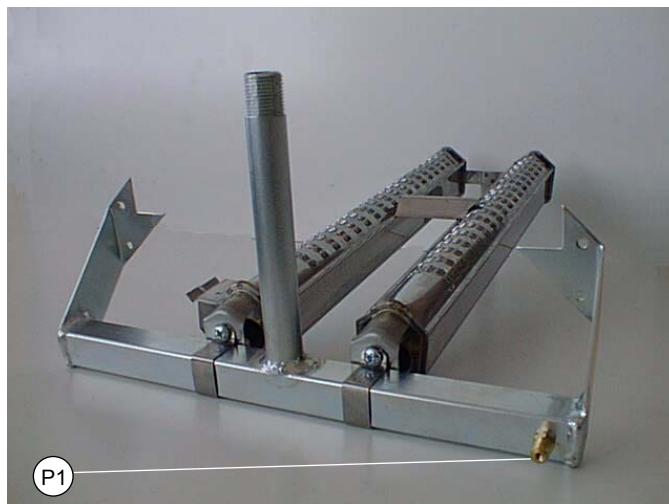

P1 Connector for

Figure 26 – Connector for measurement of gas pressure

## 5.2 HOW TO CHANGE GAS TYPE



**You will need:** the heater connected to the power and gas supply.



Change of gas type must be carried out by **professionally qualified personnel**. Incorrect or careless assembly of the gas circuit may cause dangerous gas leaks from all of the circuit and in particular from zones that are tampered with. Use, in addition, adequate sealants on all connections.

If the type of gas indicated by the label does not correspond to the one to be used, the appliance must be converted and adapted to the type of gas to be used.

To carry out this operation, proceed as follows:

1. Disconnect the gas and power supply.
2. Replace the nozzles with ones of a suitable diameter for the type of gas to be used (see Table 12). Remember to fit the copper washers located between nozzle and manifold.
3. Next proceed with regulation of the appliance as described in “HOW TO REGULATE THE GAS VALVE”.
4. Replace the sticker indicating the type of gas applied to the appliance with one indicating the new type of gas.

NATURAL GAS AND L.P.G. NOZZLES				
		M 20 C	M 30 C	M 60 C
Natural gas (G20)	diameter (mm)	2.80	4.00	4.00
GPL (G30-G31)	diameter (mm)	1.6/1.8	2.20	2.2/2.3

Table 12 – M C series nozzles



## 5.3 MAINTENANCE

Careful maintenance is always at the basis of economy and safety.

Maintenance for heating units must be carried out, preferably at the beginning of winter, **by qualified service engineers.**

For correct, prolonged operation, general cleaning of the appliance is recommended at least once a year (giving particular attention to the heat exchangers and fan grilles), as well as combustion tests as applicable under specific regulations.

## 5.4 OPERATING ANOMALIES

Before checking for possible failures, ensure that:

- A) Correct electric supply: 230-240V  $\pm$ 10% 50Hz and adequate earthing are provided.
- B) The gas is supplied.
- C) Pressures and flows are within the limits recommended by the manufacturer. A pressure lower than the given limits will result in insufficient gas inlet. The causes for this may be the following:

*If the unit is fed with natural Gas:*

- a) Poor gas meter performance.
- b) The length of the pipes and the number of elbows are excessive with respect to the diameter.

*If the unit is fed with L.P.G.:*

- a) It can happen that after the first time the burner turns off, the unit locks out at the moment of ignition. In this case it may be that the reducer flow is insufficient.
- b) If the required pressure is not reached, it may be either that the meter does not provide adequate flow or the length of the pipes and the number of elbows are excessive with respect to the diameter.

Only at this point proceed with the specific trouble shooting.

### WARNING

Before opening the side door to access the control panel, CUT OUT THE POWER SUPPLY to the unit using the omnipolar switch.

## 5.5 TYPES OF FAULT AND POSSIBLE ACTIONS

In case of a failure, call a qualified service engineer.

### CASE NO. 1: THE UNIT LOCKS OUT DURING THE FIRST IGNITION PHASE.

- D) The ignition electrode is broken or badly positioned.
- E) The flame sensor is broken or incorrectly positioned or touches the unit ground.

### NOTE

For correct burner ignition, the distance of the ignition electrode from the burner head should be between 4 mm and 6 mm.

- F) Failure in the flame control unit or in its electrical connections.
- G) Failure in the gas valve or in its electrical connections.
- H) Soft opening pressure too low.
- I) Check that the unit has a good earth.
- J) Air is inside the gas pipes.

#### **CASE NO. 2: THE UNIT LOCKS OUT DURING OPERATION.**

- K) The gas supply is suddenly cut off due to a failure in the gas system. The ignition control repeats the ignition cycle, after which the gas valve closes locking out the unit (accidental gas inlet cut off).
- L) The power supply is suddenly cut off due to a failure in the electrical supply mains. If the electrical cut off period is prolonged, the temperature limit thermostat (M1) locks out the unit, thus preventing re-ignition. When electricity returns, push the reset button which is placed on the thermostat, inside the unit control panel, below the black screw plug (accidental power supply break).
- M) The flame sensor touches the unit ground or it is disconnected.
- N) The gas valve does not open due to a failure of the valve itself or of its electrical connections.

#### **CASE NO. 3: THE TEMPERATURE LIMIT THERMOSTAT (M1) STOPS THE BURNER.**

- O) The heat exchangers have overheated. Check the operation of the fan, gas pressure and nozzles.
- P) The exchangers overheat due to accumulation of dirt. Clean the exchangers (dirt can also obstruct ventilation and supply grille).

To reset the thermostat push the button placed on the thermostat inside the unit control panel, under the black screw plug.

#### **CASE NO. 4: THE BURNER GOES OUT AND DOES NOT RE-IGNITE EVEN IF ROOM TEMPERATURE REQUIRES IT.**

- Q) Check the performance of the room thermostat and its electrical connections.
- R) Check the position of the room thermostat (check that it is not influenced by external heat sources).

#### **CASE NO. 5: THE EXHAUST FAN WILL NOT START.**

- S) Check that the room thermostat is set on the desired temperature.
- T) Check the electrical connections of the exhaust fan and its capacitor.
- U) Check integrity of the unit's protection fuse.
- V) Make sure that neither the limit nor the safety thermostat have operated.



**CASE NO. 6: THE EXHAUST FAN STARTS BUT THE UNIT DOES NOT IGNITE.**

- W) Intake and/or exhaust duct are obstructed or too long.
- X) The electrical or pneumatic connections of the pressure switch are faulty
- Y) The flame control unit does not start the cycle: replace the internal fuse of the flame control unit or the control unit itself.
- Z) Pressure switch out of setting: replace or adjust it.

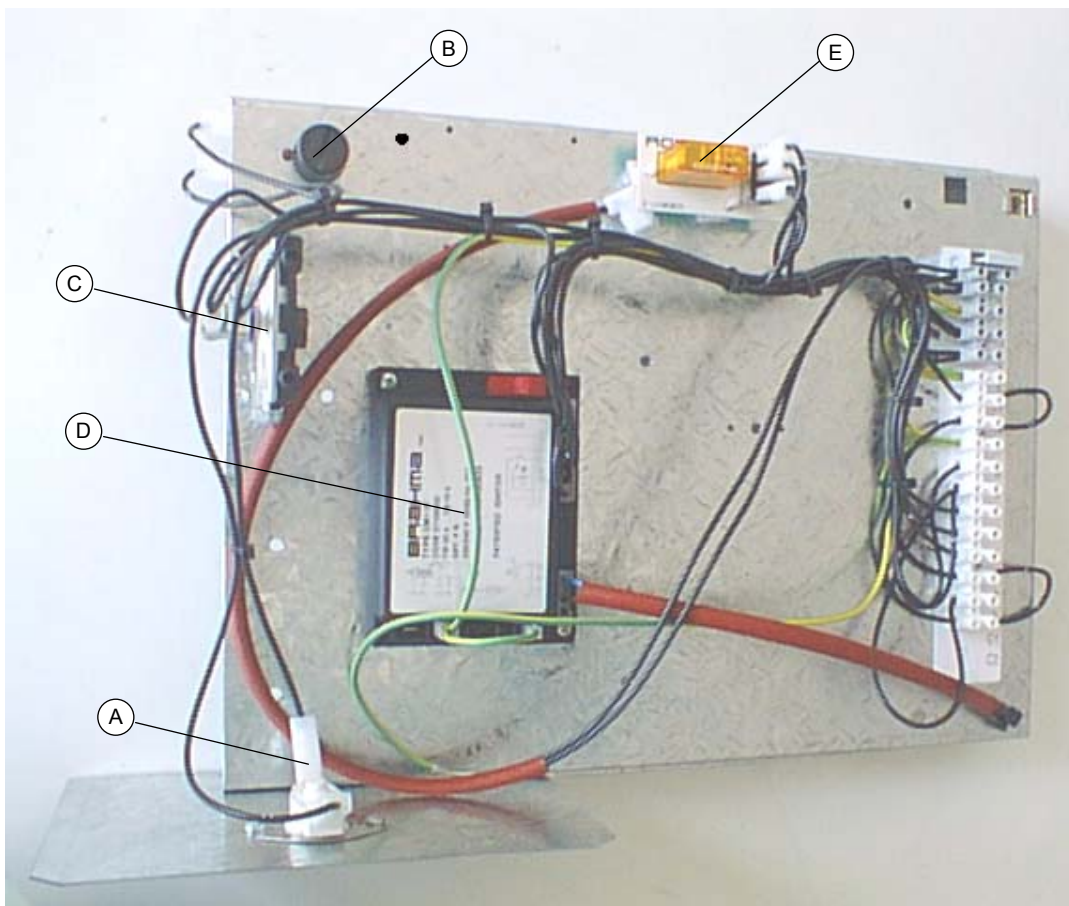

- A) Safety thermostat
- B) Temperature limit thermostat
- C) Air pressure switch
- D) Flame control unit
- E) Pressure switch control relay

**Figure 27** – Electrical panel

## TROUBLESHOOTING FLOWCHART FOR UNIT HEATERS

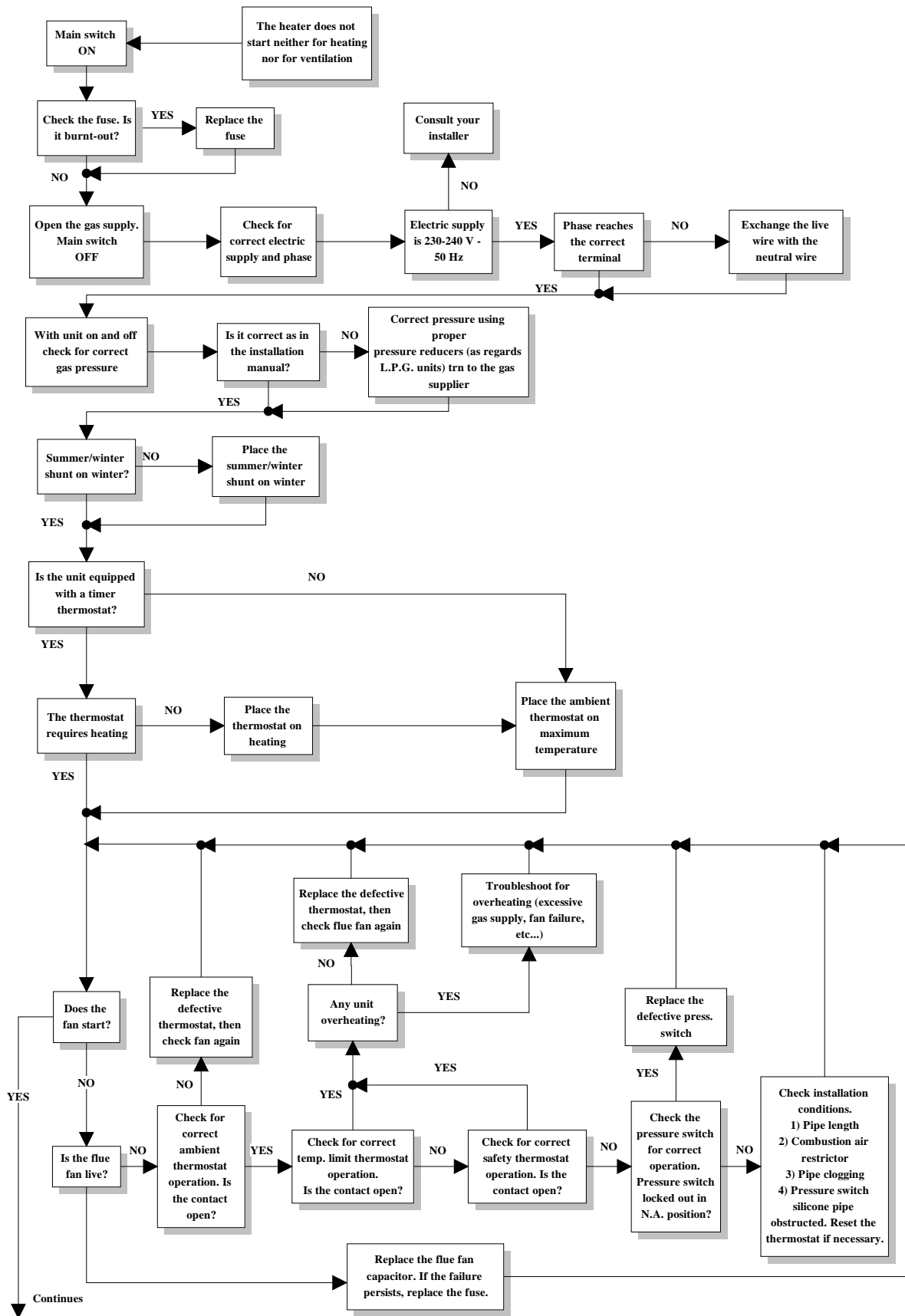

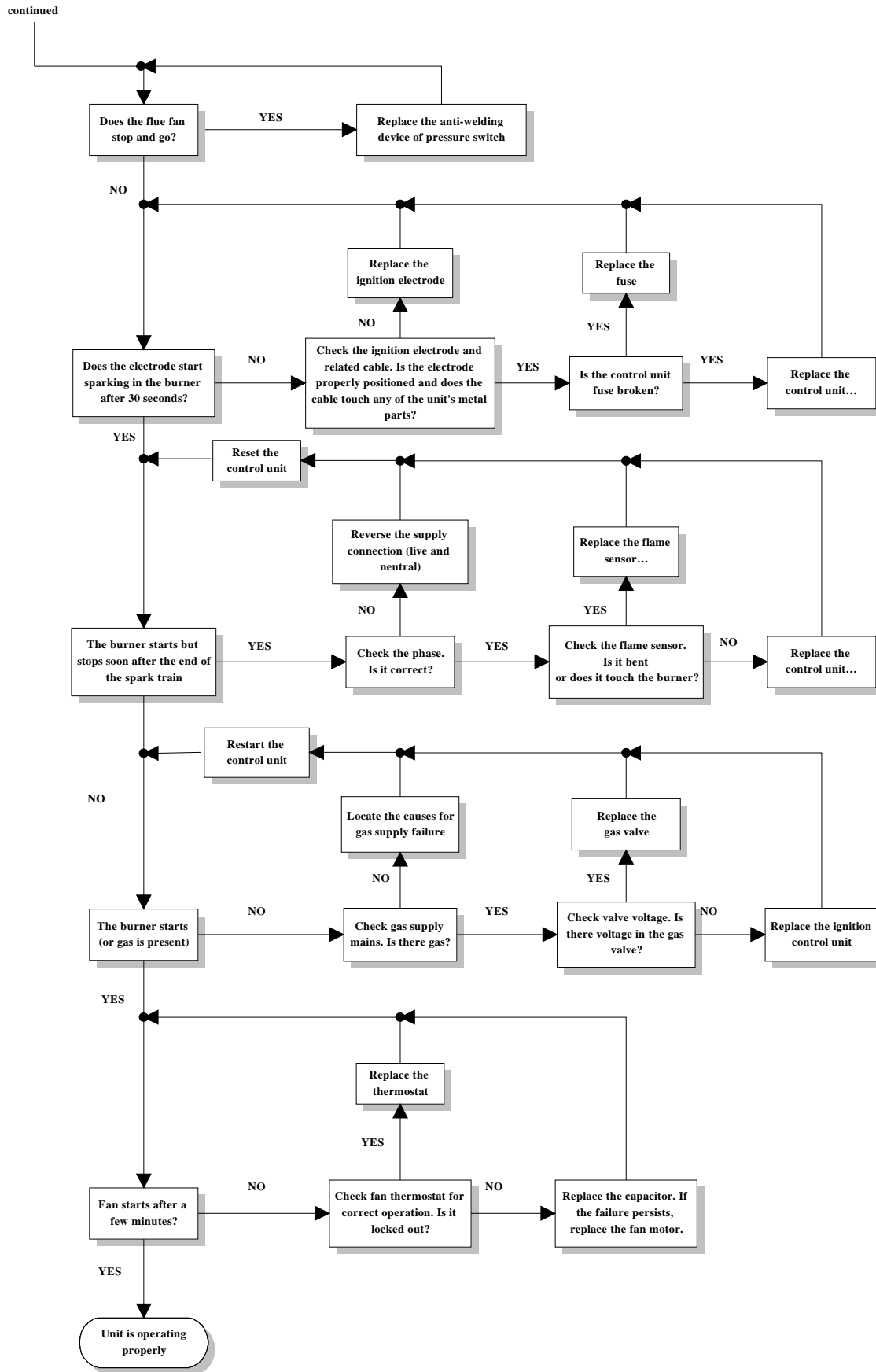





## SECTION 6: ACCESSORIES

This section contains a list of accessories available for the installation and use of the M C series heaters.

 For pressure drops associated with the accessories, refer to Table 8 on page 26.

### MIXING CHAMBER

The mixing chamber allows the ventilation air intake to be connected to the outside.

The chamber is ready to fit on the rear part of the heater and allows it to be connected to both rear and lower air intake ducts. Removable blind panels are fitted on the side to allow the centrifugal fan to be serviced.

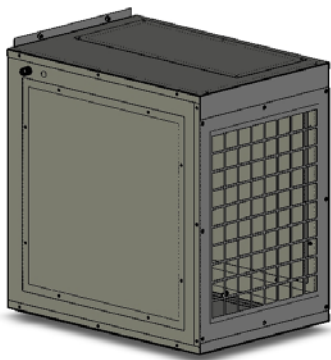
	CHAMBER FOR M 20 C	O-CSS000
	CHAMBER FOR M 30 C	O-CSS001
	CHAMBER FOR M 60 C	O-CSS002

### FILTER HOLDER

The filter holders allow the air filters to be installed.

The filter holders can be installed either behind or below the mixing chamber.

	FILTER HOLDER 400 X 500 FOR M 20 C	O-STF014
	FILTER HOLDER 500 X 500 FOR M 30 C	O-STF015
	FILTER HOLDER 500 X 1,000 FOR M 60 C	O-STF016

## AIR FILTER

Class G3 air filter (EN 779) to be fitted in the special filter holder.

For M 60 series heaters, two filters must be used for each intake side (rear or lower).

	AIR FILTER 400 X 500 FOR M 20 C	O-FLT013
	AIR FILTER 500 X 500 FOR M 30 C	O-FLT012
	AIR FILTER 500 X 1,000 FOR M 60 C	N. 2 O-FLT012

## AIR FLOW ADJUSTMENT DAMPERS

The dampers allow the adjustment of intake air in the rear or lower part.

The dampers can be installed either behind or below the mixing chamber.

The damper(s) must never be completely closed, as this would mean an absence of air intake on the part of the centrifugal fan.

	DAMPERS 400 X 500 FOR M 20 C	O-SRR000
	DAMPERS 500 X 500 FOR M 30 C	O-SRR001
	DAMPERS 500 X 1,000 FOR M 60 C	O-SRR002



## ANTI-VIBRATION JOINTS

These make it possible to connect the rear and front combustion air intake ducts to the mixing chamber, preventing potential vibrations.

	ANTI-VIBRATION JOINT 400 X 500 FOR M 20 C	O-GTV018
	ANTI-VIBRATION JOINT 500 X 500 FOR M 30 C	O-GTV019
	ANTI-VIBRATION JOINT 500 X 1,000 FOR M 60 C	O-GTV020

## LOWER SUPPORT BEAMS

These enable the heater/mixing chamber combination to be fixed to the support bracket.

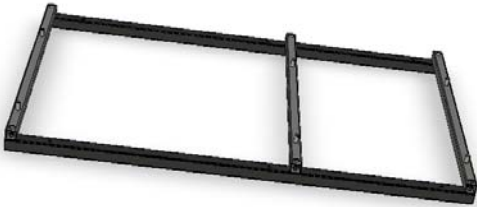
	LOWER SUPPORT BEAMS FOR M 20 C	O-SPP004
	LOWER SUPPORT BEAMS FOR M 30 C	O-SPP005
	LOWER SUPPORT BEAMS FOR M 60 C	O-SPP006

## SUPPORT BRACKETS

	SUPPORT BRACKETS M 20 C M 30C M 60 C	O-STF017
---	---	----------

Muoverci dinamicamente,  
nella ricerca, sviluppo e diffusione  
di prodotti sicuri, ecologici, a basso consumo  
energetico, attraverso la consapevole responsabilità  
di tutti i collaboratori.

## La Mission Robur



  
coscienza ecologica

Robur Spa  
tecnologie avanzate  
per la climatizzazione  
Via Parigi 4/6  
24040 Verdellino/Zingonia (Bg) Italy  
T +39 035 888111 F +39 035 884165  
www.robur.it robur@robur.it