

1 DESCRIPTION

The Next-R series gas unit heaters are modulating devices, on two heat output levels, with fixed air flow fans.

They are characterized by a high thermal efficiency, despite their very low weight and dimensions.

Available in three different versions and seven heat output sizes, they adapt to any direct exchange heating demand.

In addition to the version with axial fans, the Next-R series gas unit heaters are also available with centrifugal fans for delivery air ducting and also in a vertical downflow version (Paragraph 2 p. 7).

This last system solution allows to hang the gas unit heaters near

the roof and to obtain a vertical downflow (typical solution in cases of heating of warehouses and storage of material that require the presence of high racking that would prevent the horizontal air throw).

The Next-R series gas unit heaters can be managed and controlled in different ways: from a simple on/off control, to a zone control for the management of 10 devices, up to a remote control via PC on which a specific software developed by Robur allows the single management of up to 100 gas unit heaters (Paragraph 4.3 p. 12).

2 AVAILABLE RANGE

Next-R gas unit heaters are available in three versions:

- ▶ with horizontal flow, with axial fan (Next-R series, from 14,1 to 76,4 kW)
- ▶ with horizontal flow, ductables, with centrifugal fan (Next-R C series, from 25,5 to 76,4 kW)
- ▶ with vertical downflow (Next-R V series, from 25,5 to 44,6 kW)



Choosing the correct flow direction

Due to characteristics and positioning of internal components, Next-R V vertical downflow gas unit heaters cannot be used for horizontal flow operation, and vice versa, horizontal flow gas unit heaters cannot under any circumstances be used for vertical downflow operation.

3 SPECIFICATION OF SUPPLY

Direct exchange gas unit heater fired by natural gas/LPG with sealed chamber and forced draught, with heat output modulation on two levels and fixed air flow rate, designed to be installed inside the room to be heated and equipped with:

- ▶ Stainless steel multigas premix burner.
- ▶ High head blower.
- ▶ Control board for brushless motor of the blower.
- ▶ Corrugated stainless steel heat exchangers with very large exchange surface (R15, R20 models).
- ▶ Heat exchangers, made out of a special aluminium die-cast alloy, with a very high heat exchange capacity (models R30, R40, R50, R60, R80).

The gas unit heater is suitable for the type of installation B23, C13, C33, C53, C63.

Axial fan models

Axial fan models with high air flow, available in 7 sizes of heat output (R15, R20, R30, R40, R50, R60, R80).

Centrifugal fan models

Models with high head centrifugal fan, equipped with flange for

the connection of any air ducting, available in 4 sizes of heat output (R30 C, R40 C, R50 C, R80 C).

Vertical downflow models

Axial fan models with high air flow, designed for ceiling mounting with vertical downflow, available in 3 sizes of heat output (R30 V, R40 V, R50 V).

Axial fan models with high air flow, with optional revolving support bracket for vertical downflow, available in 2 sizes of heat output (R15, R20).

3.1 CONTROL AND SAFETY DEVICES

- ▶ 100 °C limit thermostat with manual reset against heat exchangers overheating.
- ▶ Differential pressure switch for controlling the correct operation of the blower (all models except R15, R20).
- ▶ Fan thermostat (for R30, R40, R50, R60, R80 models).
- ▶ Ventilation timer (for R15, R20 models).
- ▶ Gas solenoid valve.
- ▶ Controller for ignition, adjustment and flame control.

4 FEATURES AND TECHNICAL DATA

4.1 DIMENSIONS

4.1.1 Axial gas unit heaters

4.1.1.1 R15/R20

Figure 4.1 Unit dimensions

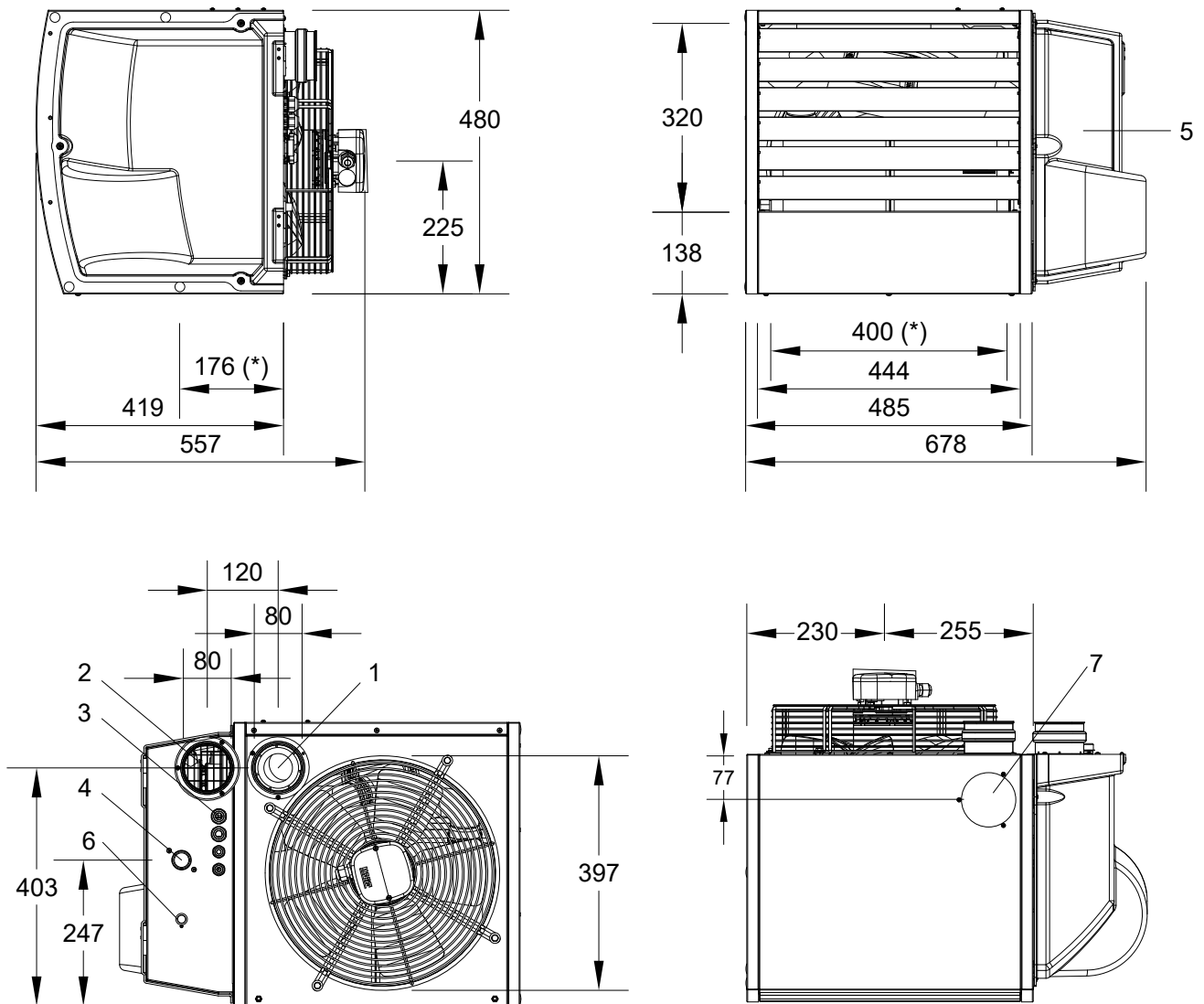

- 1 Flue gas exhaust
- 2 Combustion air inlet
- 3 Power supply cables input
- 4 Gas connection 3/4" M

- 5 Thermoformed door
- 6 Limit thermostat reset button
- 7 Flue gas exhaust blind cover, alternative to the rear one (1)
- (*) Holes for fixing to the support bracket

4.1.1.2 R30

Figure 4.2 Unit dimensions

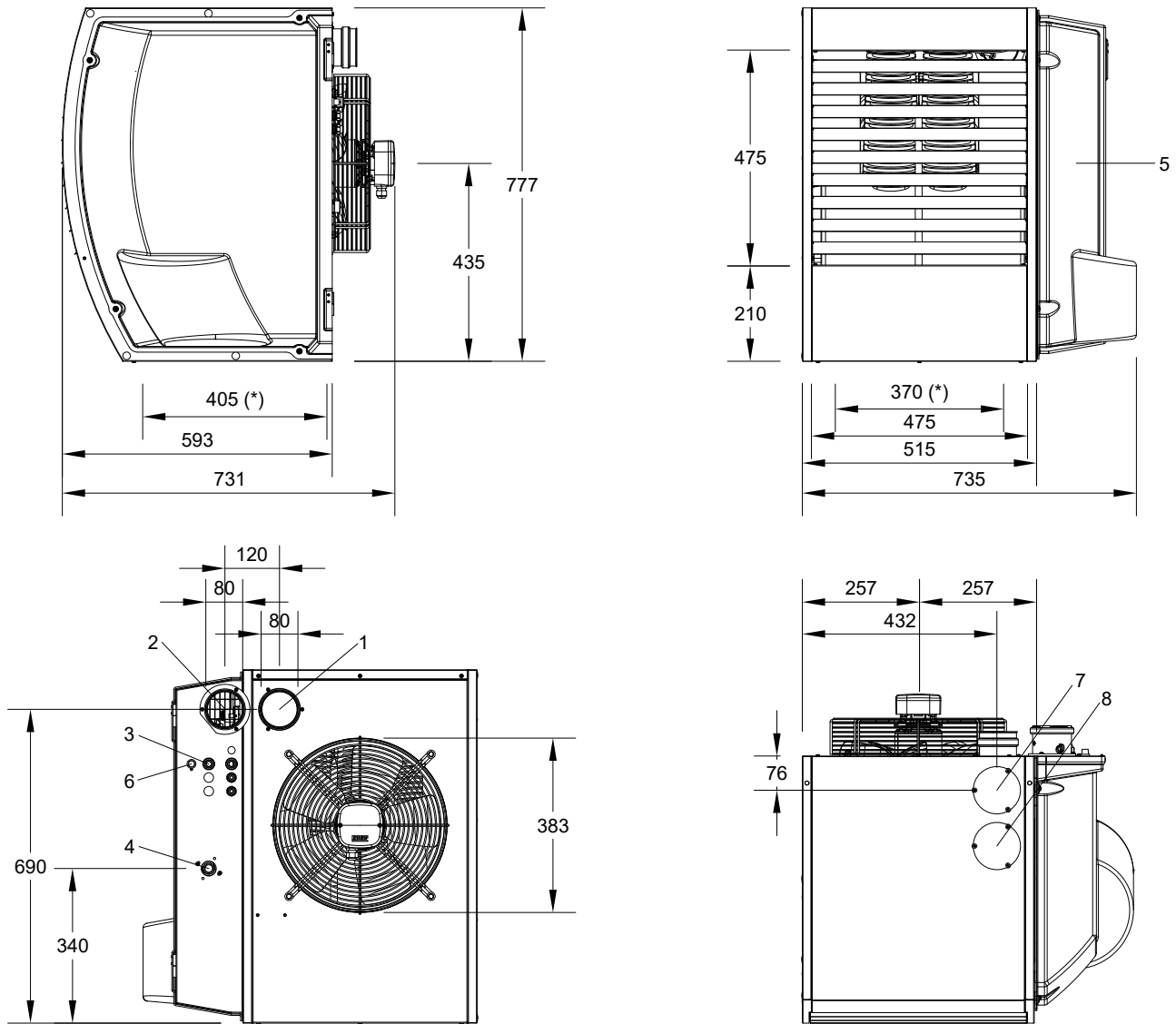

- 1 Flue gas exhaust
- 2 Combustion air inlet
- 3 Power supply cables input
- 4 Gas connection 3/4" M
- 5 Thermoformed door
- 6 Limit thermostat reset button
- 7 Flue gas exhaust blind cover, alternative to the rear one (1)
- 8 Blind cover for access to the fan thermostat
- (*) Holes for fixing to the support bracket

4.1.1.3 R40

Figure 4.3 Unit dimensions

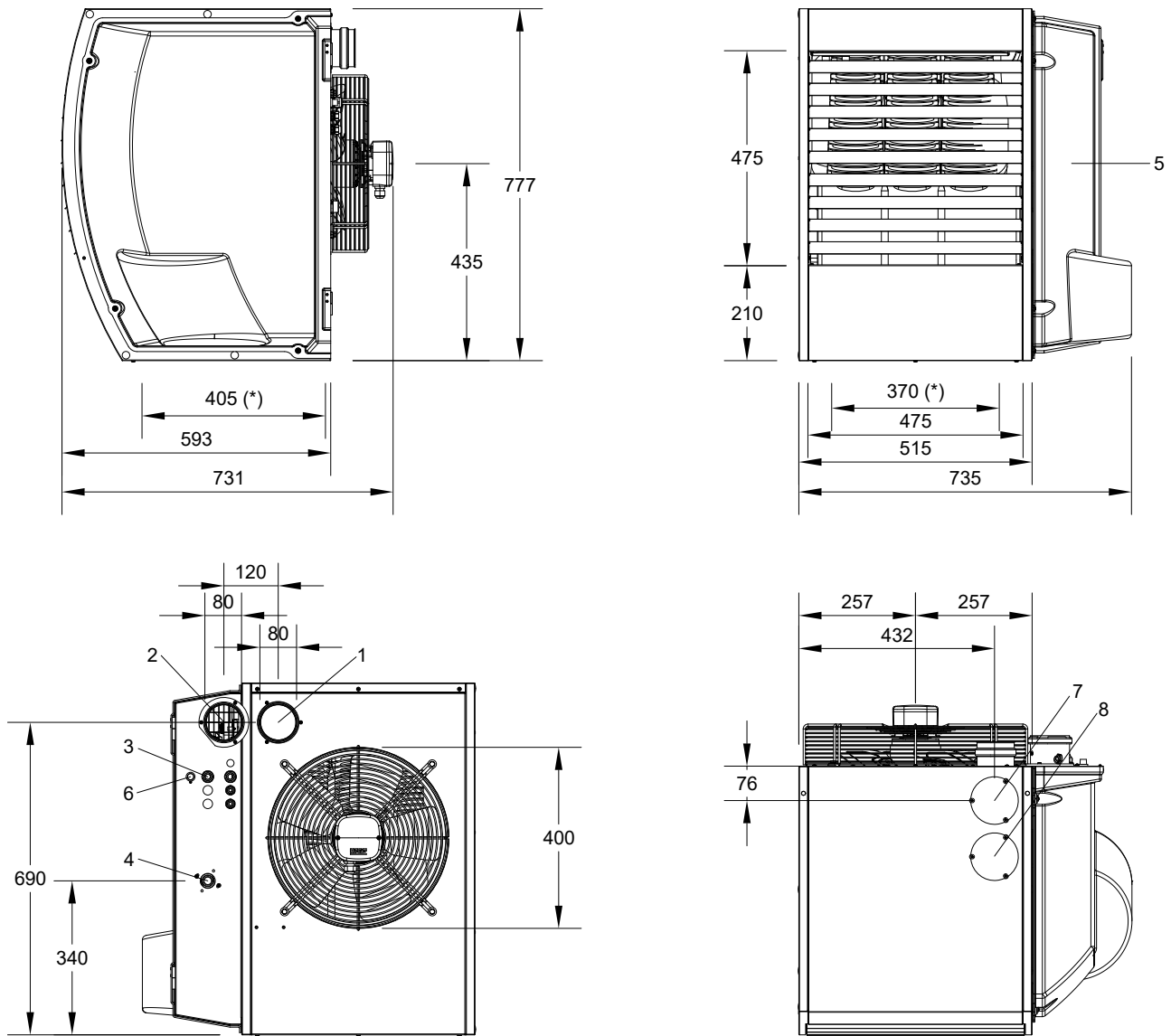

- 1 Flue gas exhaust
- 2 Combustion air inlet
- 3 Power supply cables input
- 4 Gas connection 3/4" M
- 5 Thermoformed door

- 6 Limit thermostat reset button
- 7 Flue gas exhaust blind cover, alternative to the rear one (1)
- 8 Blind cover for access to the fan thermostat
- (*) Holes for fixing to the support bracket

4.1.1.4 R50

Figure 4.4 Unit dimensions

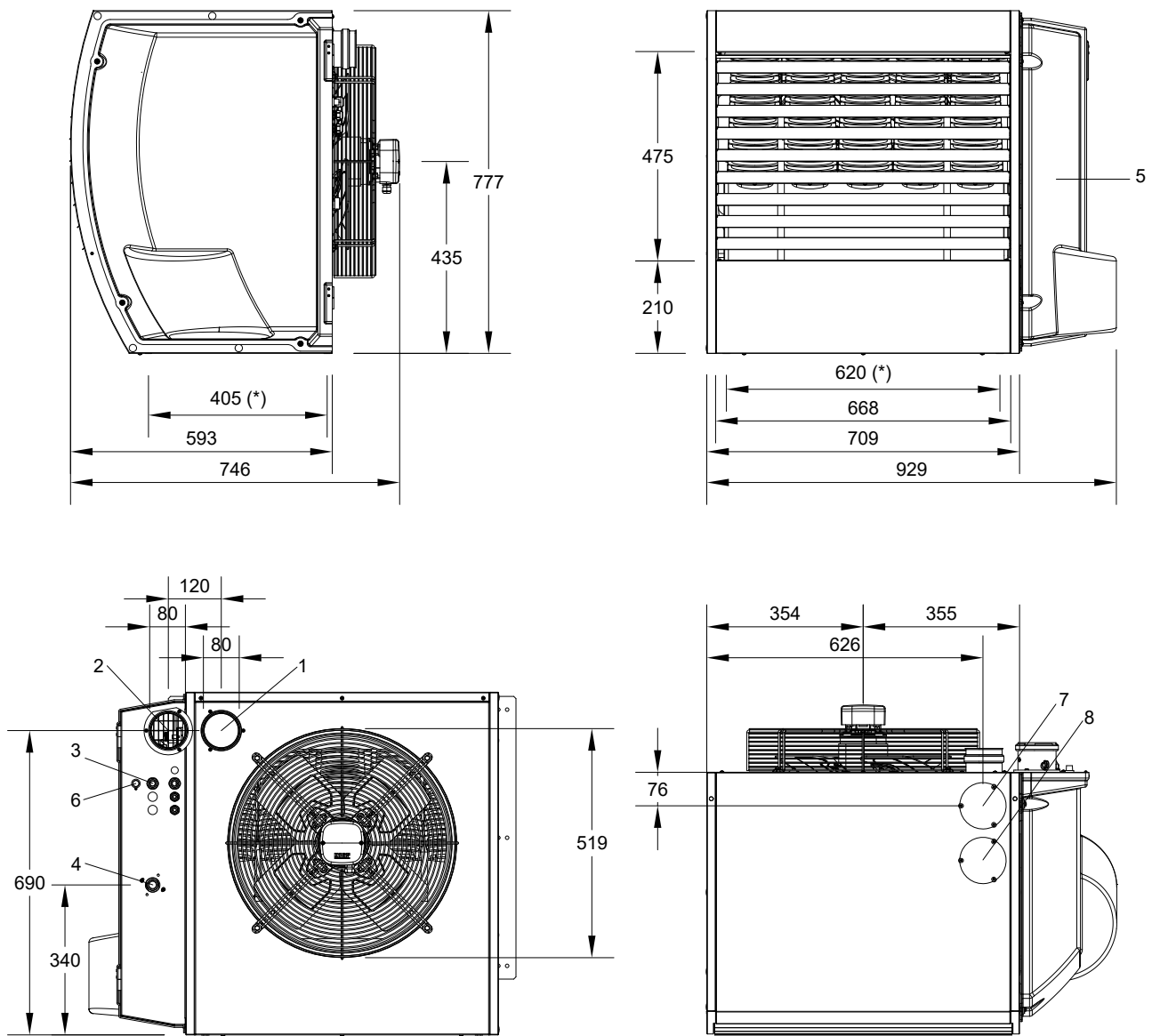

- 1 Flue gas exhaust
- 2 Combustion air inlet
- 3 Power supply cables input
- 4 Gas connection 3/4" M
- 5 Thermoformed door
- 6 Limit thermostat reset button
- 7 Flue gas exhaust blind cover, alternative to the rear one (1)
- 8 Blind cover for access to the fan thermostat
- (*) Holes for fixing to the support bracket

4.1.1.5 R60

Figure 4.5 Unit dimensions

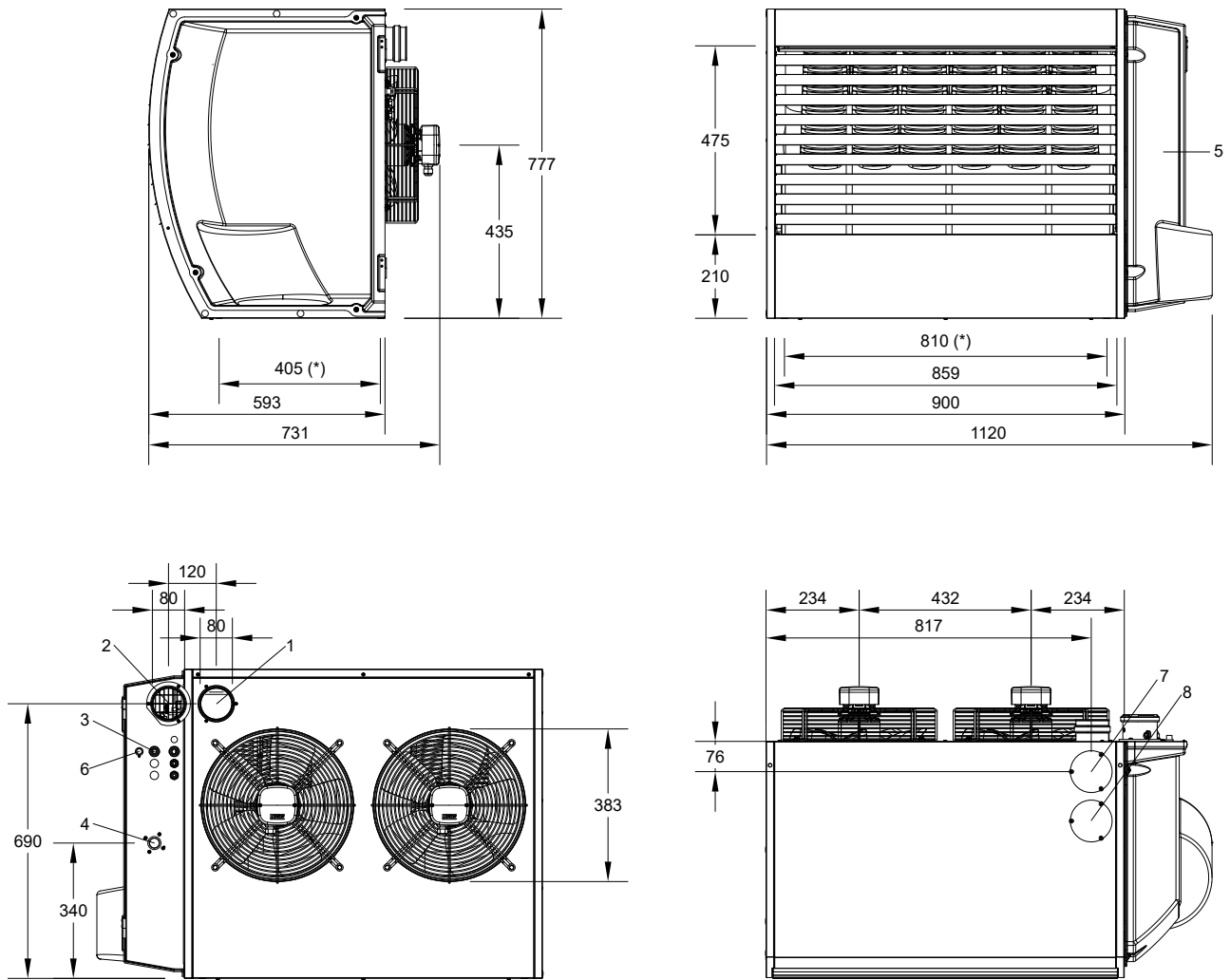

- 1 Flue gas exhaust
- 2 Combustion air inlet
- 3 Power supply cables input
- 4 Gas connection 3/4" F
- 5 Thermoformed door
- 6 Limit thermostat reset button
- 7 Flue gas exhaust blind cover, alternative to the rear one (1)
- 8 Blind cover for access to the fan thermostat
- (*) Holes for fixing to the support bracket

4.1.1.6 R80

Figure 4.6 Unit dimensions

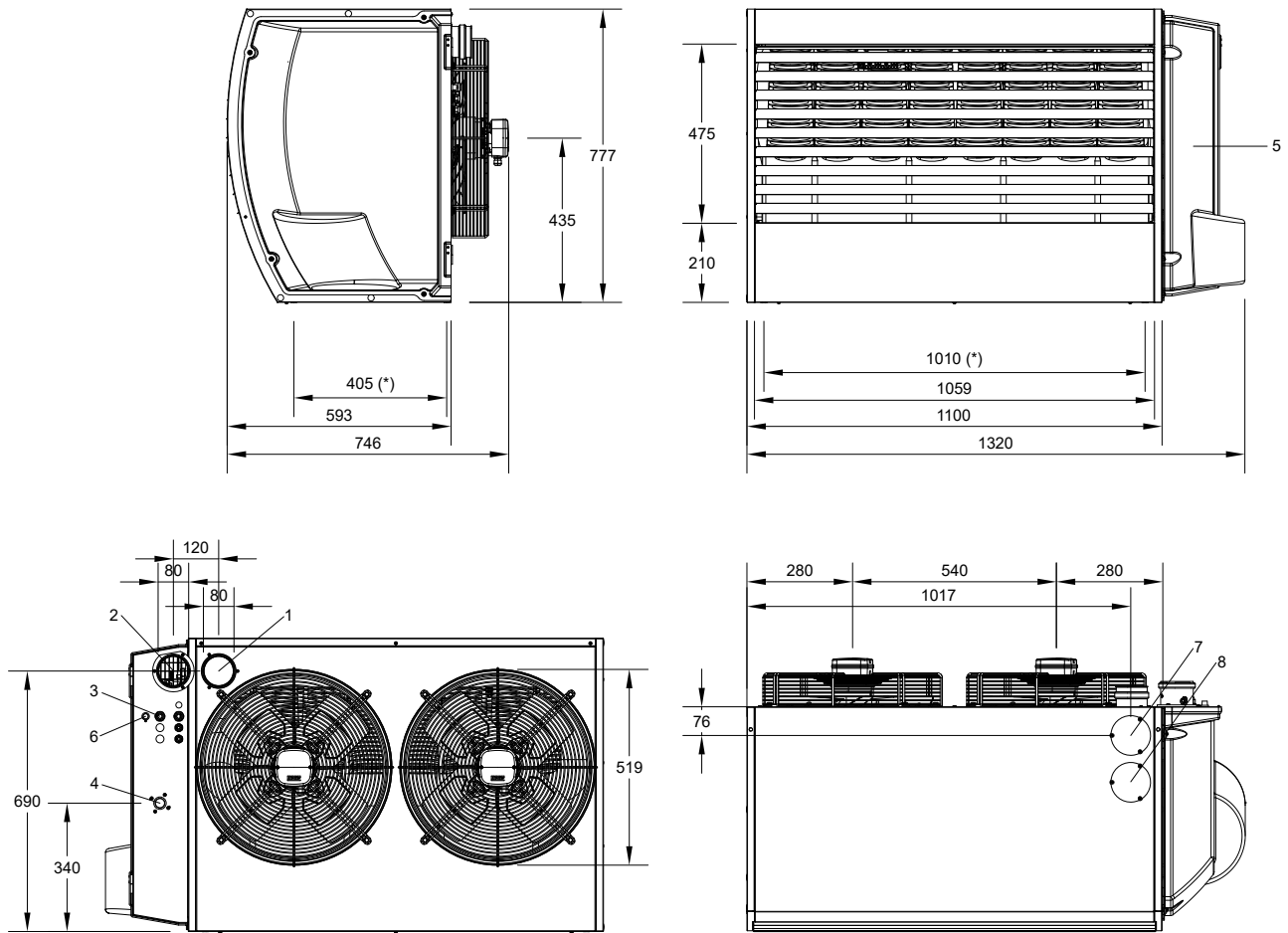

- 1 Flue gas exhaust
- 2 Combustion air inlet
- 3 Power supply cables input
- 4 Gas connection 3/4" F
- 5 Thermoformed door
- 6 Limit thermostat reset button
- 7 Flue gas exhaust blind cover, alternative to the rear one (1)
- 8 Blind cover for access to the fan thermostat
- (*) Holes for fixing to the support bracket

4.1.2 Centrifugal gas unit heaters (Next-R C)

4.1.2.1 R30 C

Figure 4.7 Unit dimensions

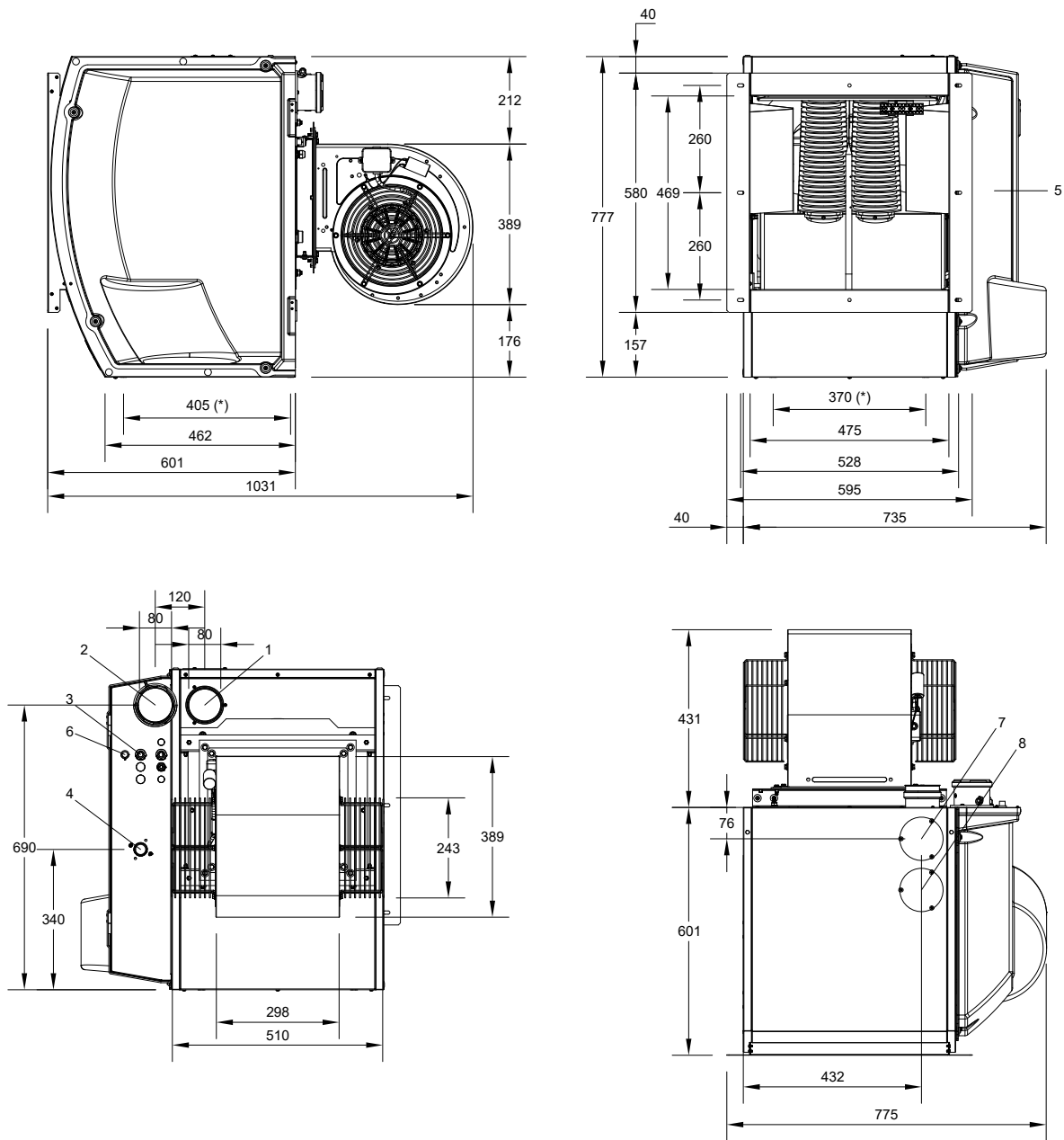

- 1 Flue gas exhaust
- 2 Combustion air inlet
- 3 Power supply cables input
- 4 Gas connection 3/4" M
- 5 Thermoformed door
- 6 Limit thermostat reset button
- 7 Flue gas exhaust blind cover, alternative to the rear one (1)
- 8 Blind cover for access to the fan thermostat
- (*) Holes for fixing to the support bracket

4.1.2.2 R40 C

Figure 4.8 Unit dimensions

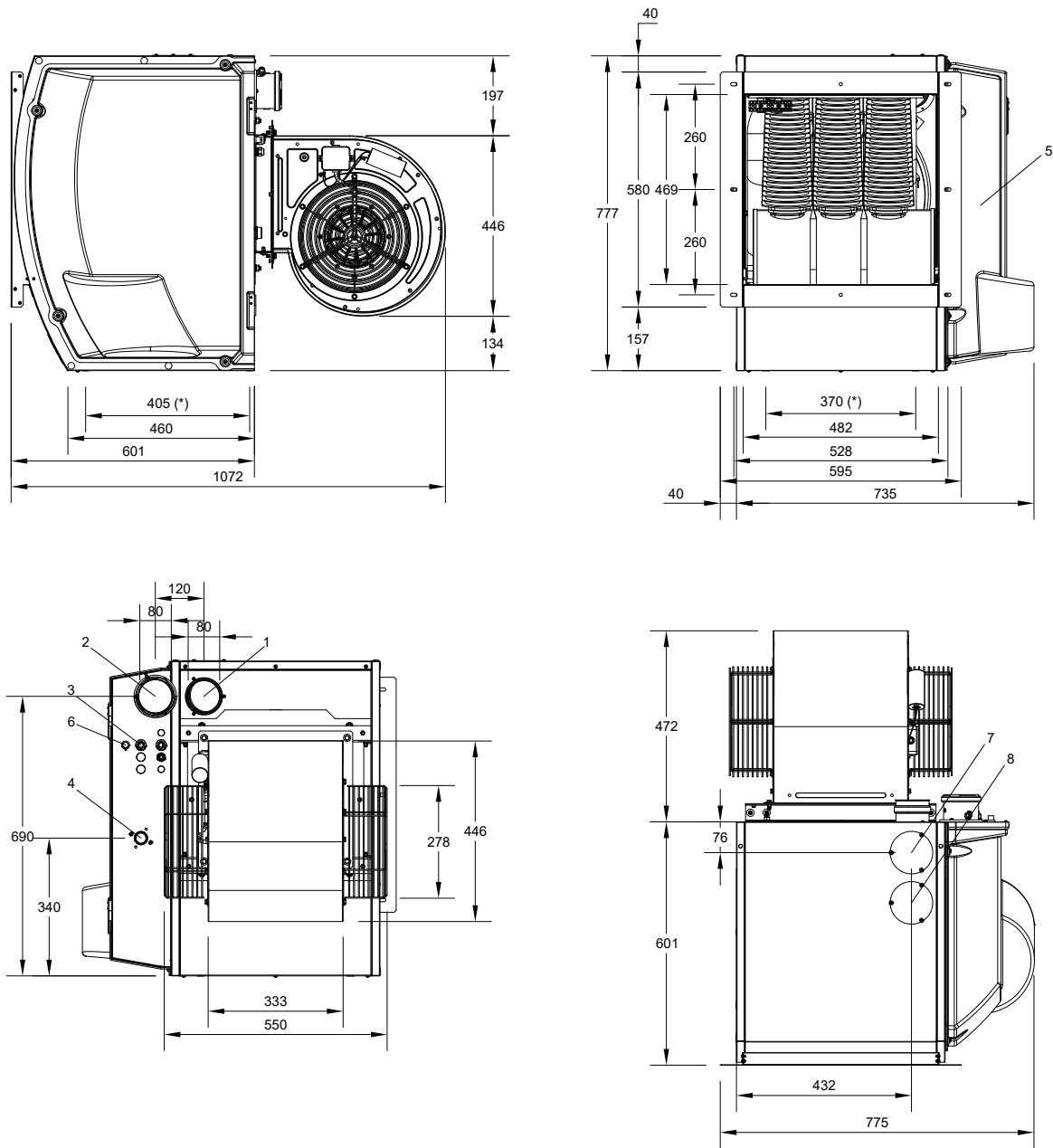

- 1 Flue gas exhaust
- 2 Combustion air inlet
- 3 Power supply cables input
- 4 Gas connection 3/4" M
- 5 Thermoformed door
- 6 Limit thermostat reset button
- 7 Flue gas exhaust blind cover, alternative to the rear one (1)
- 8 Blind cover for access to the fan thermostat
- (*) Holes for fixing to the support bracket

4.1.2.3 R50 C

Figure 4.9 Unit dimensions

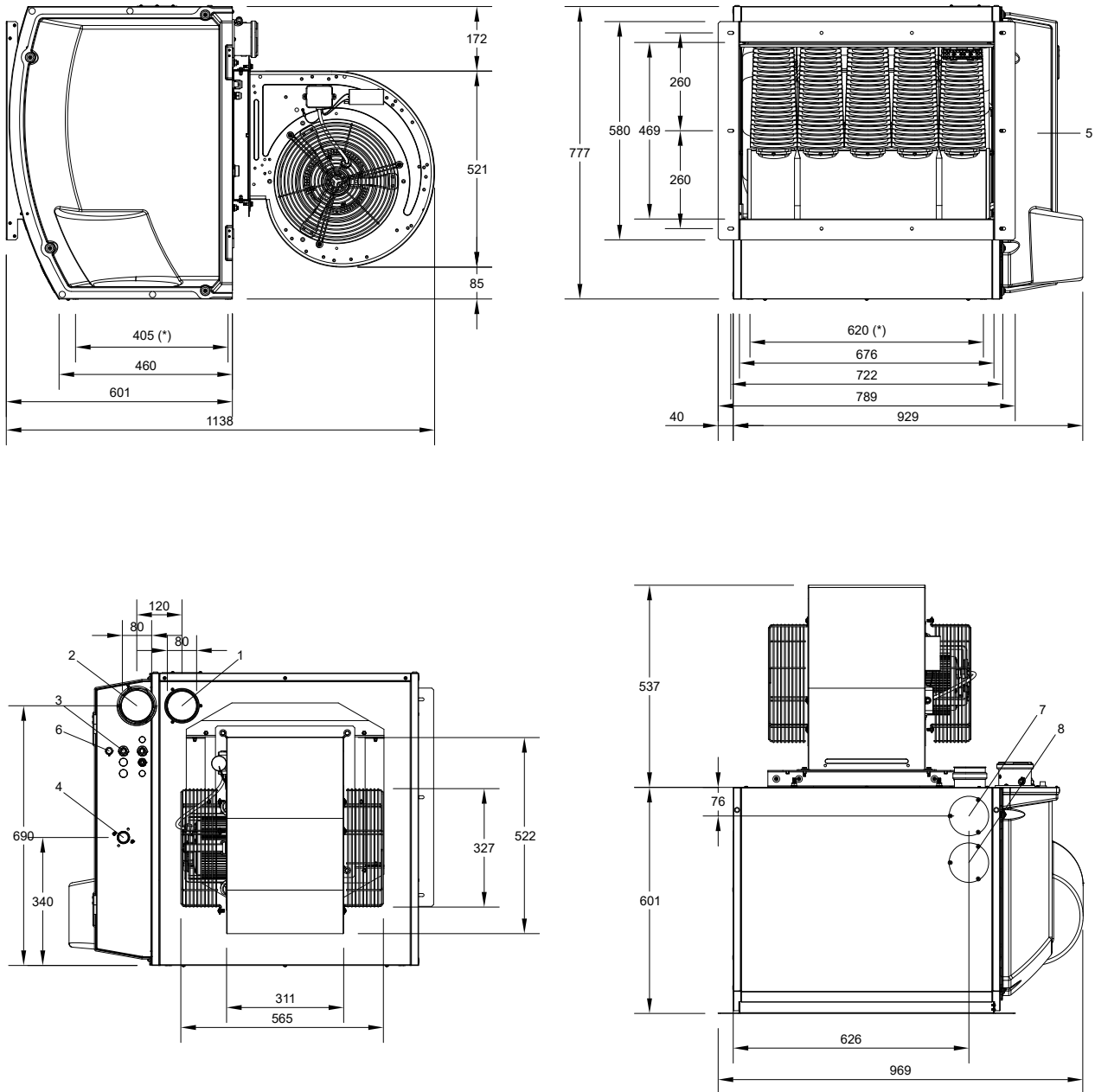

- 1 Flue gas exhaust
- 2 Combustion air inlet
- 3 Power supply cables input
- 4 Gas connection 3/4" M
- 5 Thermoformed door
- 6 Limit thermostat reset button
- 7 Flue gas exhaust blind cover, alternative to the rear one (1)
- 8 Blind cover for access to the fan thermostat
- (*) Holes for fixing to the support bracket

4.1.2.4 R80 C

Figure 4.10 Unit dimensions

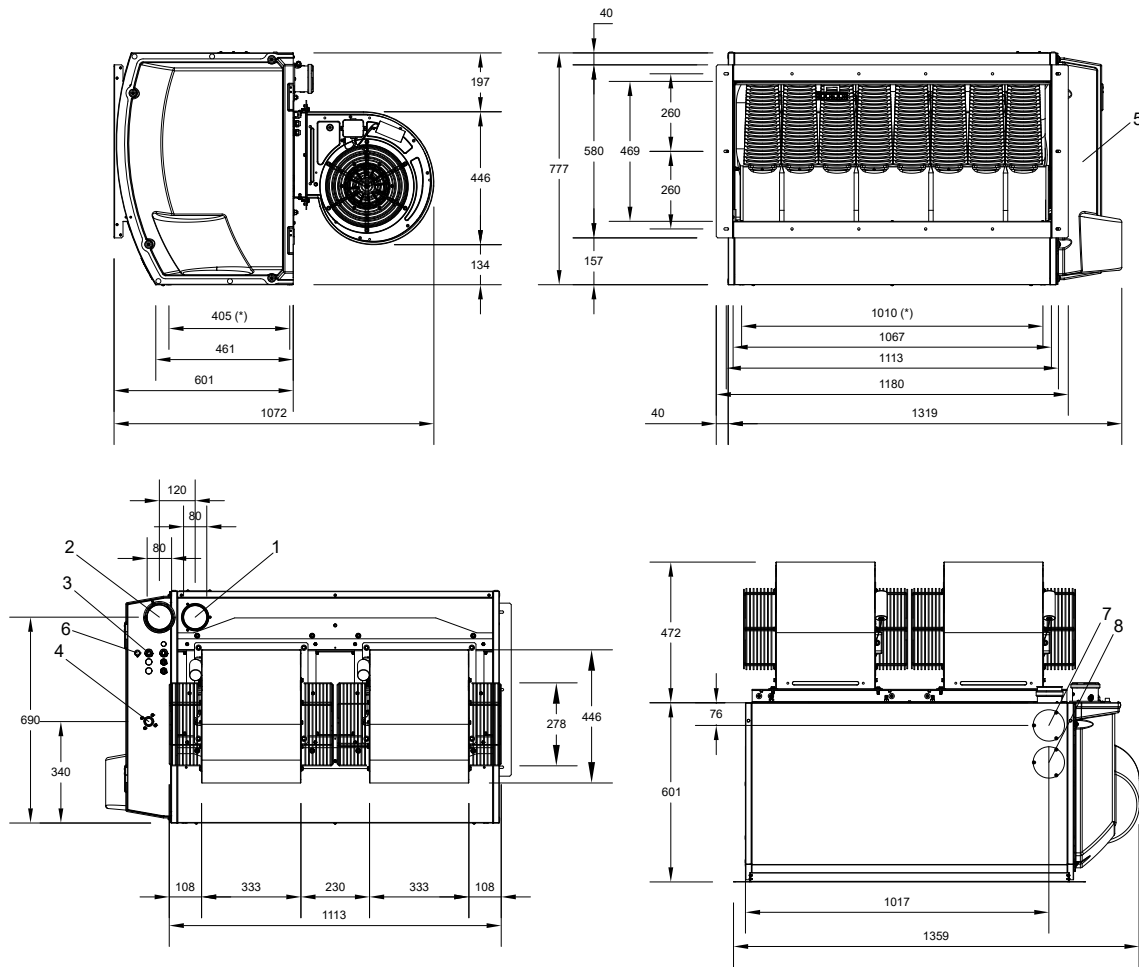

- 1 Flue gas exhaust
- 2 Combustion air inlet
- 3 Power supply cables input
- 4 Gas connection 3/4" F
- 5 Thermoformed door
- 6 Limit thermostat reset button
- 7 Flue gas exhaust blind cover, alternative to the rear one (1)
- 8 Blind cover for access to the fan thermostat
- (*) Holes for fixing to the support bracket

4.1.3 Vertical downflow gas unit heaters (Next-RV)

The dimensions of the vertical downflow gas unit heaters are identical to those of the corresponding axial models (Paragraph

4.1.1 p. 2).

Figure 4.11 p. 11 below details the centre distances between the vertical suspension brackets for the different models of vertical downflow gas unit heaters.

Figure 4.11 Position of vertical downflow gas unit heaters brackets

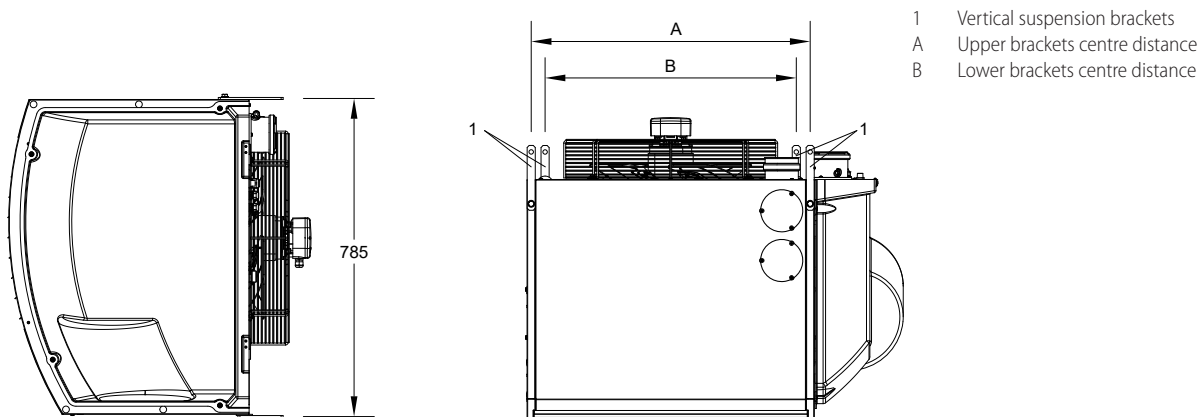

Table 4.1 Centre distance of the vertical suspension brackets

Model	A	B
R30 V	494	370
R40 V	494	370
R50 V	688	620

4.2 OPERATION MODE

The Next-R gas unit heater can be operated on two heat output levels (maximum and minimum), keeping the fan speed constant.

To select the power level it is necessary to use a suitable control device (Paragraph 4.3 p. 12).

4.3 CONTROLS

4.3.1 Control device

The appliance may only work if it is connected to a control device, selected from:

1. OCDS012 1-key basic control
2. OCTR000 2-key basic control
3. OTRG005 thermoregulator
4. OCDS008 digital chronothermostat (only in association with OTRG005 thermoregulator)
5. OSWR000 Genius software for remote management of gas unit heaters (only in association with OTRG005 thermoregulator)
6. External request



Refer to Section C01.04 for further details about control devices.

4.4 TECHNICAL DATA

Table 4.2 Technical data

Axial fan models

			R15	R20	R30	R40	R50	R60	R80	
Heating mode										
Heat input	nominal (1013 mbar - 15 °C) (1)	kW	15,5	20,5	28,0	38,3	49,0	69,0	84,0	
	minimum (1)	kW	10,3	13,2	16,8	23,0	31,0	41,4	54,0	
Heat output for each unit	nominal	kW	14,1	18,7	25,5	35,0	44,6	62,8	76,4	
	minimum	kW	9,9	12,7	16,3	22,2	30,3	40,4	52,6	
Efficiency	nominal heat input	%	91,0			91,5		91,0		
	minimal heat input	%	96,0	96,5	96,7	96,5	97,8	97,5	97,4	
	useful at 100% heat input	%	90,7			91,2	90,6	90,5	90,6	
Heat losses	to flue in operation	%	9,00			8,50		9,00		
	to casing in operation	%	0,30				0,40	0,50	0,40	
	with burner off	%	0,25							
Temperature rise	nominal heat input	K	18,6	22,0	25,0	24,8	26,4	27,4	25,0	
	minimal heat input	K	13,0	15,0	15,9	15,7	18,0	17,6	17,2	
length of throw (residual speed < 0,5 m/s) (2)		m	13,0	15,0	18,0	20,0	25,0	28,0	40,0	
Outdoor temperature (dry bulb)	maximum	°C	35							
	minimum	°C	-15						0	
Electrical specifications										
Power supply	voltage	V	230							
	type	-	single-phase							
	frequency	Hz	50							
Electrical power absorption	nominal	kW	0,18	0,21	0,30	0,34	0,41	0,60		
fuse		A	6,3							
Degree of protection	fan motor	IP	54							
	appliance	IP	20							
Installation data										
Gas consumption	G20 natural gas (nominal)	m ³ /h	1,64	2,17	2,96	4,05	5,18	7,30	8,89	
	G25 (nominal)	m ³ /h	1,91	2,52	3,45	4,71	6,03	8,49	10,34	
	G25.1 (nominal)	m ³ /h	1,91	2,52	3,44	4,71	6,02	8,48	10,32	
	G25.3 (nominal)	m ³ /h	1,86	2,47	3,37	4,61	5,90	8,30	10,11	
	G27 (nominal)	m ³ /h	2,00	2,65	3,61	4,94	6,33	8,91	10,84	
	G2.350 (nominal)	m ³ /h	2,28	3,01	4,12	5,63	7,20	10,14	-	
	G30 (nominal)	kg/h	1,22	1,62	2,21	3,02	3,86	5,44	6,63	
	G31 (nominal)	kg/h	1,20	1,59	2,17	2,98	3,81	5,36	6,53	
Air flow	nominal (Delta T = 15 °C)	m ³ /h	2222	2460	2900	4010	4770	6470	8670	
Gas connection	type	-	M					F		
	thread	"	3/4							
Flue gas exhaust	diameter (Ø)	mm	80							
	residual head	Pa	70			90	80	100	130	
	type of installation	-	B23, C13, C33, C53, C63							
Combustion air intake connection	diameter (Ø)	mm	80							

(1) Relative to NCV (net calorific value).

(2) Values measured in an open area at maximum air flow. In a real installation, the thermal flow may reach greater distances than those given here (depending on the height of the ceiling and its thermal insulation).

		R15	R20	R30	R40	R50	R60	R80	
recommended height	m	2,2	2,5	3,0 ÷ 3,5					
sound power L_w (max)	dB(A)	74,5	75,5	77,0	78,0	81,0	82,0	90,5	
sound pressure L_p at 5 metres (max)	dB(A)	52,5	53,5	55,0	56,0	59,0	60,0	68,5	
Dimensions	width	678		735		929	1120	1320	
	depth	557		731		746	731	746	
	height	480		777					
Weight	in operation	kg	26	28	51	56	64	78	91
General information									
number of heat exchangers	-	1	2		3	5	6	8	
type of heat exchangers	-	pipe			tower				
number of fans	-	1					2		

(1) Relative to NCV (net calorific value).

(2) Values measured in an open area at maximum air flow. In a real installation, the thermal flow may reach greater distances than those given here (depending on the height of the ceiling and its thermal insulation).

Centrifugal fan models

		R30 C	R40 C	R50 C	R80 C	
Electrical specifications						
Electrical power absorption	nominal	kW	0,38	0,68	1,38	1,40
fuse		A	6,3		10,0	
Degree of protection	fan motor	IP	44			
	appliance	IP	20			
Installation data						
Air flow	at maximum available head	m ³ /h	1900	3400	4700	7000
	nominal (Delta T = 15 °C)	m ³ /h	2900	4000	5350	8550
maximum useful pressure head		Pa	120		240	120
minimum pressure drop on heat flow delivery		Pa	0	50		
Dimensions	width	mm	775		969	1359
	height	mm	777			
	depth	mm	1031	1072	1138	1073
Weight	in operation	kg	68	80	92	129

Vertical downflow models

R30 V	R40 V	R50 V
The technical data of these models are identical to those of the corresponding axial models, with the exception of the installation height		

4.5 CENTRIFUGAL GAS UNIT HEATERS (NEXT-R C)

The Next-R C series gas unit heaters can be used by ducting the heat flow delivery.

For this reason, this version of gas unit heater has replaced the front grille with directional louvres for direct throw with a flat flange to which the delivery air ducting can be connected, with an anti-vibration joint at the connection.

The ducting sizing must take into account the minimum air flow allowed for the gas unit heater and the maximum available centrifugal fan head (both shown in Table 4.2 p. 12).

Next-R C gas unit heaters, although they can be ducted, must be installed inside buildings.



Refer to Section C01.07 for further information on air ducting.